

Piano Sonata

Chris Dench

holograph edition

# WHITEOUT

## HAZILY

ACCEL.

$\text{♩} = 48$

$\text{♩} = 60$  RALL.

pppp

5:4

5:4

5:4

5:4

5:4

5:4

7:8

7:8

7:8

PEDAL

D<sub>4</sub>  
C<sub>4</sub>  
B<sub>3</sub>

(NON TROPPO)

$\text{♩} = 48$

5:4

5:4

5:4

5:4

5:4

5:4

5:4

5:4

5:4

5:4

5:4

7:8

7:8

7:8

7:8

7:8

7:8

mf

ppp

PED.

D<sub>4</sub>  
C<sub>4</sub>  
B<sub>3</sub>  
A<sub>3</sub>

(HALF-RELEASES)

(57)

$\text{♩} = 54$

2

Handwritten musical score for the first system. It consists of two staves: a piano staff (top) and a bass staff (bottom). The score is marked with various time signatures and dynamics. Above the piano staff, there are several measures with a time signature of  $\text{♩} = 54$ , followed by a section with  $\text{♩} = 48$ , and then a section with  $\text{♩} = 58$ . The piano staff contains complex rhythmic patterns, including sixteenth and thirty-second notes, and rests. The bass staff contains a simpler rhythmic pattern, primarily eighth and sixteenth notes. Dynamic markings include  $\text{pppp}$ ,  $\text{pppp}$ ,  $\text{f}$ , and  $\text{f}$ . There are also markings for  $\text{7:8}$  and  $\text{5:4}$  time signatures. A  $\text{ped}$  marking is present at the beginning. A  $\text{sim}$  marking is also visible.

Handwritten musical score for the second system. It consists of two staves: a piano staff (top) and a bass staff (bottom). The score is marked with various time signatures and dynamics. Above the piano staff, there are several measures with a time signature of  $\text{♩} = 48$ , followed by a section with  $\text{♩} = 52$ , and then a section with  $\text{♩} = 48$ , and finally a section with  $\text{♩} = 55$ . The piano staff contains complex rhythmic patterns, including sixteenth and thirty-second notes, and rests. The bass staff contains a simpler rhythmic pattern, primarily eighth and sixteenth notes. Dynamic markings include  $\text{pppp}$ ,  $\text{pppp}$ ,  $\text{p}$ , and  $\text{pppp} // (\text{mf})$ . There are also markings for  $\text{7:8}$  and  $\text{5:4}$  time signatures. A  $\text{ped}$  marking is present at the beginning.

→ (♩=48)

# THREE WINDOWS $\downarrow = 86$ SLOWLY, COLDLY — AS IF HEARD THROUGH MIST

5"  $\overbrace{\quad\quad\quad}^{3 \text{ } 7:8}$   $\overbrace{\quad\quad\quad}^{7:8}$   $\overbrace{\quad\quad\quad}^{7:8}$   $\overbrace{\quad\quad\quad}^{7:8}$

mf  $\overbrace{\quad\quad\quad}^{5:4}$   $\overbrace{\quad\quad\quad}^{7:8}$   $\overbrace{\quad\quad\quad}^{7:8}$   $\overbrace{\quad\quad\quad}^{7:8}$

B4 F4 A4 (pppp) (c4)

(PED.) (CATCH RESONANCE) UC (SUSTAIN THROUGHOUT)

$\overbrace{\quad\quad\quad}^{7:8}$   $\overbrace{\quad\quad\quad}^{3:2}$   $\overbrace{\quad\quad\quad}^{5:4}$   $\overbrace{\quad\quad\quad}^{3:2}$

(pppp)  $\overbrace{\quad\quad\quad}^{3:2}$   $\overbrace{\quad\quad\quad}^{5:4}$   $\overbrace{\quad\quad\quad}^{3:2}$  (pppp) (B4)

(PED.) UC

$\overbrace{\quad\quad\quad}^{3:2}$   $\overbrace{\quad\quad\quad}^{5:4}$   $\overbrace{\quad\quad\quad}^{3:2}$   $\overbrace{\quad\quad\quad}^{3:2}$

pppp!  $\overbrace{\quad\quad\quad}^{(7)}$   $\overbrace{\quad\quad\quad}^{5:4}$   $\overbrace{\quad\quad\quad}^{3:2}$   $\overbrace{\quad\quad\quad}^{3:2}$  (pppp)!

(PED.) UC

Handwritten musical score for the first system. It consists of a treble staff and a bass staff. The treble staff contains a melodic line with various rhythmic groupings: a 3:2 measure, followed by a 3:2 measure, a 5:4 measure, a 5:4 measure, a 3:2 measure, a 5:4 measure, and a 5:4 measure. The bass staff provides harmonic support with chords and single notes. Dynamic markings include *(pppp)* and *pppp!*. Pedal and sustain markings are present: *(PED.)* with an arrow pointing right, and a box labeled *UC* with an arrow pointing right.

Handwritten musical score for the second system. It features a treble staff and a bass staff. The treble staff begins with a 10-second rest, indicated by a vertical line and the text "10''". The tempo is marked as  $\text{♩} = 86$ . The music resumes with a melodic line in the treble staff, including a 3:2 measure, a 3:2 measure, and a 7:8 measure. The bass staff continues with harmonic accompaniment. Dynamic markings include *(pppp)* and *STILL pppp*. Pedal and sustain markings include *(PED.)* with an arrow, and a box labeled *TC* with an arrow pointing right.

Handwritten musical score for the third system. It consists of a treble staff and a bass staff. The treble staff continues the melodic line with rhythmic groupings of 5:4, 7:8, 3:2, and 5:4. The bass staff provides harmonic support. Dynamic markings include *(pppp)* and *(A4)*. Pedal markings include *(PED.)* with an arrow pointing right.

Handwritten musical score for the first system. The system consists of a treble clef staff and a bass clef staff. The treble staff begins with a key signature of one flat (Bb) and a common time signature. It contains several measures of music, including a triplet of eighth notes marked *pppp*. Above the staff, there are several bracketed time signature markings:  $5:4$ ,  $9:8$ , and  $5:4$ . The bass staff contains a series of chords and notes, with a  $9:8$  marking above it. A *ppp* dynamic marking is present in the middle of the system. Below the bass staff, there is a *(PED.)* marking with an arrow pointing to the right.

Handwritten musical score for the second system. The system consists of a treble clef staff and a bass clef staff. The treble staff continues with the key signature of one flat. It features a  $7:6$  marking above the first few measures, followed by  $5:4$  markings. The bass staff contains chords and notes, with *ppp* and *(A4)* markings. A *(PED.)* marking with an arrow is at the beginning. The system concludes with a *ppp* marking and a  $5:4$  marking.

Handwritten musical score for the third system. The system consists of a treble clef staff and a bass clef staff. The treble staff begins with a key signature of one flat and contains a  $3:2$  marking. It features several measures of music, including a *ppp* marking. The bass staff contains chords and notes, with *ppp* and  $5:4$  markings. The system concludes with a double bar line and a diagonal line. A *(PED.)* marking with an arrow is at the beginning.

Handwritten musical score for the first system. The system includes a piano staff (top) and a bass staff (bottom). The piano staff begins with a tempo marking of  $\text{♩} = 86$ . The music features various intervals and ratios, including  $5:6$ ,  $7$ ,  $7:8$ , and  $3:2$ . A dynamic marking of  $(pppp)$  is present. Chord diagrams are shown above the piano staff, and a bass line with notes  $C, D, E, F, G, B, \flat$  is written below the bass staff. A pedal point is indicated by  $(PED.)$  with an arrow pointing to the right.

Handwritten musical score for the second system. It continues the piano and bass staves. The piano staff includes a  $(pppp)$  dynamic marking and intervals such as  $5:4$ ,  $3:2$ , and  $5:6$ . A  $7$  interval is also marked. Chord diagrams are shown above the piano staff, and a bass line with notes  $A, B, \flat, C, D, E, F, \sharp$  is written below the bass staff. A pedal point is indicated by  $(PED.)$  with an arrow pointing to the right.

Handwritten musical score for the third system. It continues the piano and bass staves. The piano staff includes a  $(pppp)$  dynamic marking and intervals such as  $5:4$ ,  $3:2$ , and  $5:4$ . A  $7$  interval is also marked. Chord diagrams are shown above the piano staff, and a bass line with notes  $F, G, B, \flat, B, \flat, D, \flat, E, \flat$  is written below the bass staff. A pedal point is indicated by  $(PED.)$  with an arrow pointing to the right.

Handwritten musical score for the first system, featuring treble and bass staves. The treble staff contains a melodic line with various rhythmic values and accidentals. The bass staff shows a complex harmonic accompaniment with many accidentals. Above the treble staff, there are several bracketed intervals:  $9:8$ ,  $3:2$ ,  $7:8$ ,  $5:4$ , and  $3:2$ . A dynamic marking  $(ppp)$  is present above the treble staff. Below the bass staff, there are two sets of notes:  $(PED) \rightarrow D^b E^b F G A C$  and  $A^# B C^# D^# F^# G^#$ . The tempo is indicated as  $\text{♩} = 94$ .

EXPLOSIVELY — MAXIMUM FORTE

Handwritten musical score for the second system. The treble staff features a dense, rapid melodic passage with many accidentals, marked with  $(ppp)$  and  $mf$ . The bass staff provides a rhythmic accompaniment. Above the treble staff, there are bracketed intervals:  $5:4$ ,  $3:2$ ,  $3:2$ , and  $5:6$ . A dynamic marking  $mf$  is placed above the treble staff. Below the bass staff, there are notes and a dynamic marking  $mf$ . The tempo is indicated as  $\text{♩} = 94$ .

Handwritten musical score for the third system. The treble staff contains a melodic line with various rhythmic values and accidentals. The bass staff shows a complex harmonic accompaniment with many accidentals. Above the treble staff, there are several bracketed intervals:  $5:4$ ,  $5:4$ ,  $3:2$ ,  $7:8$ ,  $5:4$ ,  $3:2$ , and  $9:8$ . A dynamic marking  $mf$  is present above the treble staff. Below the bass staff, there are notes and a dynamic marking  $mf$ . The tempo is indicated as  $\text{♩} = 94$ .



(f) *mf* *slower*  $\downarrow = 80$

Handwritten musical score for the first system, featuring two staves with complex rhythmic markings and dynamic instructions. The notation includes various note values, rests, and accidentals. Above the staves, there are several horizontal lines with numerical values: 5, 7:8, 9:8, 115, 7:6, 5:4, 9:8, 7:6, 5:4, 9:8. Below the staves, there are more numerical values: 5:4, 9:8, 7:8, 5:4, 3:2, 7:8, 9:8, 9:8, 5:4. Dynamic markings include *mf* and *f*. A circled 'f' is present at the beginning of the first staff.

Handwritten musical score for the second system, continuing the complex rhythmic and dynamic notation. The notation includes various note values, rests, and accidentals. Above the staves, there are several horizontal lines with numerical values: 3:2, 9:8, 5:4, 7:8, 4:5, 9:8, 5:4. Below the staves, there are more numerical values: 9:8, 3:2, 7:8, 5:4, 3:2, 9:8, 3:2, 9:8, 5:4, 7:8, 9:8, 5:4. Dynamic markings include *mf* and *f*. A circled 'f' is present at the beginning of the first staff.

$\downarrow = 90$  *mf* *f*

Handwritten musical score for the third system, concluding the piece with dynamic markings and numerical annotations. The notation includes various note values, rests, and accidentals. Above the staves, there are several horizontal lines with numerical values: 3:2, 7:6, 115, 3:2, 5:4, 9:8, 7:6, 9:8, 7:6, 9:8, 5:4. Below the staves, there are more numerical values: 5:4, 3:2, 3:2, 3:2, 3:2, 3:2, 6:5, 9:8, 5:4, 9:8, 5:0. Dynamic markings include *mf* and *f*. A circled 'f' is present at the beginning of the first staff.

Handwritten musical score system 1, measures 5-10. The system consists of two staves. Measure 5 is marked with a circled  $\frac{4}{4}$ . Above the staves, various time signature changes are indicated:  $5=4$ ,  $\frac{1}{7}$ ,  $\frac{3}{3}$ ,  $\frac{7}{8}$ ,  $\frac{4}{4}$ ,  $\frac{4}{6}$ ,  $\frac{3}{1}$ ,  $\frac{7}{2}$ ,  $3=2$ ,  $5=4$ ,  $\frac{6}{5}$ ,  $7=8$ , and  $\frac{10}{4}$ . Below the staves, more time signature changes are noted:  $9=8$ ,  $3=2$ ,  $5=4$ ,  $3=2$ ,  $3=2$ ,  $3=2$ ,  $3=2$ ,  $3=2$ , and  $5=4$ . Dynamic markings include  $mf$  and  $ff$ .

Handwritten musical score system 2, measures 11-12. The system consists of two staves. Measure 11 is marked with a circled  $\frac{4}{4}$ . Above the staves, time signature changes are indicated:  $\frac{2}{1}$ ,  $\frac{5}{2}$ ,  $5=4$ ,  $7=6$ ,  $\frac{3}{3}$ ,  $3=2$ ,  $7=6$ ,  $\frac{7}{8}$ ,  $7=0$ ,  $9=8$ , and  $\frac{12}{4}$ . Below the staves, time signature changes are noted:  $7=0$ ,  $5=6$ ,  $3=2$ ,  $5=6$ ,  $9=8$ ,  $3=2$ ,  $7=8$ ,  $5=4$ ,  $5=4$ , and  $5=4$ . Dynamic markings include  $ff$ .

Handwritten musical score system 3, measures 13-15. The system consists of two staves. Measure 13 is marked with a circled  $\frac{4}{4}$ . Above the staves, time signature changes are indicated:  $\frac{1}{5}$ ,  $\frac{3}{1}$ ,  $\frac{3}{2}$ ,  $\frac{1}{7}$ ,  $\frac{3}{5}$ ,  $\frac{7}{6}$ ,  $\frac{13}{4}$ ,  $\frac{1}{5}$ ,  $5=4$ ,  $\frac{5}{2}$ ,  $\frac{3}{3}$ , and  $7=8$ . Below the staves, time signature changes are noted:  $7=6$ ,  $9=8$ ,  $5=4$ ,  $7=8$ ,  $5=4$ ,  $5=4$ ,  $7=8$ ,  $7=0$ ,  $5=4$ , and  $7=8$ . Dynamic markings include  $ff$  and  $(mf)$ .

no PARSE!

CRISPLY  
2/3 CHILLY

19  
1+2 (+20)  
4.05

**COLD, SLOW**  $\downarrow = 116$

Handwritten musical score for the first system. It consists of two staves (treble and bass clef). The music is heavily annotated with rhythmic markings such as  $7/8$ ,  $5/4$ ,  $9/8$ , and  $5/2$ . Dynamic markings include  $mf$ ,  $ppp!$ , and  $pp$ . A vertical bar line is drawn through the middle of the system. Above the staves, there are various notes and symbols, including a circled '8' and a circled '19'. The tempo is indicated as  $\downarrow = 116$ .

Handwritten musical score for the second system. It continues the two-staff notation. Rhythmic markings include  $9/8$ ,  $5/4$ ,  $7/8$ ,  $5/6$ , and  $9/8$ . Dynamic markings range from  $p$  to  $mf$ . There are several slurs and phrasing marks. Above the staves, there are circled notes and symbols, including a circled '8' and a circled '19'. The tempo is indicated as  $\downarrow = 116$ .

Handwritten musical score for the third system. It concludes the piece. Rhythmic markings include  $5/4$ ,  $3/2$ ,  $9/8$ , and  $3/2$ . Dynamic markings include  $mf$  and  $pp$ . At the bottom of the system, there is a chord sequence:  $A C D F G$  with a  $5/4$  rhythm. Above the staves, there are circled notes and symbols, including a circled '8' and a circled '19'. The tempo is indicated as  $\downarrow = 116$ .

3/5  
 G C G B F  
 E = 104 WARMLY  
 DRAMATICALLY  
 9:8 p> 9:8 pp 5:4 5:4 7:6 pp 5:4 5:4 7/15 7/15 5:4

(BIAS BASS)  
 (BCDEGA)  
 5:4 5:4 5:4 5:4 5:4 5:4 5:4 5:4

6/3 5/1 3/2 5/4 1/2 7/5 7/7 6/5 5/1 3/2  
 CRES...  
 5:4 5:4 3:2 7:0 5:6 9:8 5:6 7:0 5:4 2 0

SLOWER  
 A tempo  
 SLOWER  
 1/4 7/5 2/4 6/3  
 5:4 5:4 5:6 3:2 7:0 7/4 7/5 2/4  
 7 5:4 5:4 5:4 7 5:4 5:4 5:4 7 5:4 5:4 5:4

(PP)  
 (PED) (PP) (PP)

A TEMPO, FLUIDLY

Handwritten musical score for piano, consisting of three systems of staves. The notation is dense and includes various musical symbols and annotations:

- Staff 1 (Top):** Features a treble clef and a key signature of one flat. It contains complex rhythmic patterns with notes, rests, and dynamic markings such as *pp*, *f*, and *mf*. Above the staff, there are circled numbers (5/1, 16, 1/4, 7/5, 2/7) and time signature changes (3/2, 1/6, 1/4). Pedal markings include "PED" with arrows and "L" in a circle.
- Staff 2 (Middle):** Features a bass clef and a key signature of one flat. It contains complex rhythmic patterns with notes, rests, and dynamic markings such as *p*, *mf*, and *f*. Above the staff, there are circled numbers (5/1, 16, 1/4, 7/5, 3/2, 9/8, 7/8, 3/2, 7/8, 7/8) and time signature changes (5/4, 3/2, 9/8, 7/8, 7/8). Pedal markings include "PED" with arrows and "H" in a circle.
- Staff 3 (Bottom):** Features a treble clef and a key signature of one flat. It contains complex rhythmic patterns with notes, rests, and dynamic markings such as *f*, *pp*, and *mf*. Above the staff, there are circled numbers (5/1, 1/6, 1/4, 1/5, 2/7, 6/3, 5/1, 10, 1/1) and time signature changes (5/4, 3/2, 5/4, 3/2, 5/4, 5/4). Pedal markings include "PED" with arrows and "H" in a circle.

The score is highly detailed, with numerous slurs, ties, and dynamic markings throughout. The tempo is indicated as "A TEMPO, FLUIDLY" at the top, and "AS TEMPO" appears in the lower right section.

Handwritten musical score for the first system, measures 12-14. It features two staves with complex rhythmic patterns and accidentals. Above the staves, various time signatures and ratios are written, including  $5/1$ ,  $7/8$ ,  $5/4$ ,  $3/2$ ,  $9/8$ ,  $5/6$ ,  $1/4$ ,  $7/5$ ,  $5/4$ , and  $3/2$ . Dynamic markings include  $(ff)$  and  $(f)$ . A circled  $(5/1)$  is present at the beginning of measure 12.

Handwritten musical score for the second system, measures 14-16. It continues the complex rhythmic and melodic lines. A circled  $(mf)$  is at the start of measure 14. A circled  $(ppp)$  is at the start of measure 15. A circled  $(f)$  is at the start of measure 16. The text "COLDLY" is written in large letters above the staff in measure 16. Time signatures and ratios include  $3/2$ ,  $9/8$ ,  $5/4$ ,  $3/2$ , and  $7/8$ . The word "LOCO" is written in parentheses below the staff in measure 15. A circled  $(5/1)$  is at the start of measure 14.

Handwritten musical score for the third system, measures 16-18. It features dense rhythmic textures. A circled  $(ppp)$  is at the start of measure 16. Time signatures and ratios include  $5/4$ ,  $3$ ,  $5$ ,  $3/2$ ,  $5/4$ ,  $3/2$ ,  $5/4$ ,  $20$ ,  $5/4$ ,  $5/4$ , and  $5/4$ . The word "PED" is written above the staff in measure 16. A circled  $(5/1)$  is at the start of measure 16. At the bottom right, there are additional markings:  $8$ ,  $7/8$ ,  $7/8$ , and  $ppp$ .

(PED.)

Handwritten musical score system 1. It consists of two staves. The upper staff contains a melodic line with various rhythmic values and accidentals. The lower staff contains a bass line with notes and rests. Above the upper staff, there are bracketed annotations:  $5=4$ ,  $7=8$ ,  $3=2$ ,  $3=2$ ,  $5=4$ ,  $3=2$ , and  $3=2$ . Below the lower staff, there are bracketed annotations:  $7=8$ ,  $5=4$ ,  $3=2$ ,  $5=4$ , and  $8$ . A circled '3' is written below the first few notes of the upper staff.

Handwritten musical score system 2. It consists of two staves. The upper staff contains a melodic line with various rhythmic values and accidentals. The lower staff contains a bass line with notes and rests. Above the upper staff, there are bracketed annotations:  $7=8$ ,  $3=2$ ,  $5=4$ ,  $7=8$ ,  $3=2$ , and  $3=2$ . Below the lower staff, there are bracketed annotations:  $5=4$ ,  $7=8$ ,  $7=8$ , and  $8$ . A circled '3' is written above the first few notes of the upper staff. Dynamic markings  $ppp$  and  $p$  are present below the lower staff.

Handwritten musical score system 3. It consists of two staves. The upper staff contains a melodic line with various rhythmic values and accidentals. The lower staff contains a bass line with notes and rests. Above the upper staff, there are bracketed annotations:  $3=2$ ,  $5=4$ ,  $3=2$ ,  $5=4$ ,  $3=2$ ,  $5=4$ , and  $3=2$ . Below the lower staff, there are bracketed annotations:  $5=4$ ,  $3=2$ ,  $7=8$ ,  $9=8$ ,  $7=8$ ,  $3=2$ ,  $5=4$ , and  $5=4$ . A circled '3' is written above the first few notes of the upper staff. Dynamic markings  $p$ ,  $ppp$ ,  $pp$ , and  $ppp$  are present below the lower staff.

Handwritten musical score for the first system, featuring complex rhythmic patterns and accidentals. Above the staff, various time signatures and ratios are indicated: 3:2, 5:4, 7:8, 3:2, 3:2, 3:2, 6:5, 3:2, 3, 7:6, 5:4, and 9:8. The notation includes multiple staves with notes, rests, and dynamic markings such as *ppp* and *p*. A circled 'LoCo' is present on the left side.

Handwritten musical score for the second system, continuing the complex rhythmic and melodic lines. It includes time signatures and ratios like 5:4, 3:2, 7:6, 5:4, 5:4, 8/6, 5:4, 5:4, 7:6, 7:8, and 5:4. The notation is dense with notes and accidentals, and includes dynamic markings like *ppp* and *p*. A circled '8' is visible on the left.

Handwritten musical score for the third system, showing further development of the piece. It features time signatures and ratios such as 3:2, 5:4, 3:2, 5:4, 3:2, and 7:8. The notation includes notes, rests, and dynamic markings like *ppp* and *p*. A circled '9/6' is present above the staff.



Handwritten musical score for the first system. It consists of two staves with complex rhythmic patterns. Above the staves, there are several time signature changes indicated by brackets: 3:2, 7:8, 5:4, 3:2, 3:2, 5:4, 5:4, and 9:8. The notation includes various note values, rests, and dynamic markings such as *mp* and *pp*.

Handwritten musical score for the second system. It features two staves with rhythmic notation. A tempo marking **WARM & ASSERTIVE** is written above the staff. Above this marking, a circled **G** with a flat sign ( $G^b = 68$ ) is present. Various time signatures are indicated with brackets: 7:8, 3:2, 7:8, 5:4, 5:4, 2/4, 7/2, 3:2, 6/7, 7:8/3, 5/5, 5:4, 2/4, 7/2, 4:5, and 3:2. Dynamic markings include *pp* and *f*.

Handwritten musical score for the third system. It consists of two staves with rhythmic notation. Time signatures indicated with brackets include 2:25, 3/6, 6/7, 4/3, 5/5, 5:4, 5:4, 5:4, 5:4, 3:2, 7:8, 7:8, 3:2, 3/6, 6/7, 1/1, 9:8, 3:2, 2/4, 7/2, 3/6, 5:4, and 5:4. A circled **F** is written above the staff. Dynamic markings include *p* and *f*.

6/7 1/3 5/5 (4/1) 2/4 7/2 7/6 6/7 1/3 5/5 (4/1) 2/4 1/2 3/6 6/7

5:4 7:8 5:4 5:4 7:8 3:2 7:8 5:4

5:4 3:2 5:4

5:4 7:8 7:8 7:8 5:4 9:8 5:4

(p)

7/2 3/6 6/7 #3 5/5 (4/1) 2/4 7/2 3/6 6/7 1/3 5/5

3:2 3:2 5:4 7/2 7/6 6/7 1/2 5/5 (4/1) 2/4 7/2 3/6 6/7 1/3 5/5

7:8 7:8 7:8 7:8 5:4 3:2 5:4

3:2 5:4 5:4 3:2 5:4 5:4

(p)

(4/1) 2/4 7/2 3/6 6/7 1/3 5/5 (4/1) 2/4 3/6 5/5 (4/1) 2/4 7/2 6/7

(4/1) 2/4 7/2 3/6 6/7 1/3 5/5 (4/1) 2/4 3/6 5/5 (4/1) 2/4 7/2 6/7

3:2 7:8 3:2 3:2 3:2 3:2 5:4 3:2 9:8 6/7

3:2 5:4 3:2 5:4 3:2 5:4

(f) Cresc.

27

242

mf NO PAUSE! COLDLY

Handwritten musical score for the first system. It consists of two staves. The upper staff has a treble clef and contains several measures with complex rhythmic markings, including  $5=4$ ,  $9=8$ , and  $3=2$ . The lower staff has a bass clef and contains corresponding notes. Above the staves, there are handwritten notes: "mf" and "NO PAUSE! COLDLY". Below the staves, there are dynamic markings "pp" and "p". At the bottom of the system, there are two large horizontal lines with "PED" markings and an arrow pointing to the right.

$\text{♩} = 86$

Handwritten musical score for the second system. It consists of two staves. The upper staff has a treble clef and contains several measures with complex rhythmic markings, including  $3=2$  and  $5=4$ . The lower staff has a bass clef and contains corresponding notes. Above the staves, there are handwritten notes: "pp" and "p". At the bottom of the system, there are two large horizontal lines with "PED" markings and an arrow pointing to the right.

# HEAT SINK

5=4 7=8 3=2  $\downarrow = 60$   
(WITHOUT WARNING!) 7=8 mf 3=2 5=4 3=2

(PED) p # sfz sfz sfz 5=6 3=2

5=4 mf 3=2 7. sfz (mf) p/sfz 7. 5=4 (Bb) 4=3

PIESANTE x3 p loco 5=4 30

Handwritten musical score for the first system, featuring a treble clef and a common time signature. The notation includes a melodic line with various rhythmic values and dynamic markings such as *ff*, *mf*, and *pp*. A tempo marking of  $\text{♩} = 53$  is present. A large bracket labeled *Lp* spans the first two measures. A complex chordal structure is shown in a box above the staff, with a  $9:8$  ratio indicated. The system concludes with a double bar line and a diagonal slash.

Handwritten musical score for the second system, continuing the melodic and harmonic development. It features dynamic markings like *pp*, *mf*, and *pp*, along with a  $5:4$  ratio. A bracket labeled *(PED)* is placed below the first two measures. A  $9:8$  ratio is also indicated. The system ends with a double bar line and a diagonal slash.

Handwritten musical score for the third system, which includes a bass clef and a common time signature. The notation is dense with dynamic markings such as *ff*, *mf*, *pp*, and *sfz*. It features several ratios:  $3:2$ ,  $7:8$ ,  $7:6$ , and  $5:4$ . A bracket labeled *(PED)* spans the final measures. The system concludes with a double bar line and a diagonal slash.

Handwritten musical score system 1. It features a grand staff with treble and bass clefs. The music is in a key with one sharp (F#). The system includes dynamic markings such as *mf* and *pp* (with a *(Db)* annotation). Rhythmic groupings are indicated with brackets and ratios:  $5:4$ ,  $7:8$ , and  $5:3$ . A *(PED)* marking is present at the beginning. The notation includes various note values, rests, and slurs.

Handwritten musical score system 2. This system continues the piece with dynamic markings including *pp*, *mf*, and *(ff)*. It features a *(SEMI-STAGE)* marking and *ppp* dynamics. Rhythmic groupings are marked with  $3:2$ ,  $7:8$ , and  $9:8$ . A *(PED)* marking is also present. The notation includes complex rhythmic patterns and slurs.

Handwritten musical score system 3. This system includes dynamic markings such as *ppp*, *p*, and *f* (*poco*). It features a *(PESANTE)* marking and a *(PED)* marking. Rhythmic groupings are marked with  $5:4$ ,  $3:2$ ,  $7:6$ , and  $9:8$ . The notation includes complex rhythmic patterns, slurs, and a final *(A#)* marking.

ACCCEL.

(RALL.) e sim.

Handwritten musical score for the first system. It consists of two staves with dense, complex rhythmic notation. Above the staves, there are dynamic markings: *mf*, *p*, *mf*, *fff*, *pp*, *mf*, *pp*, *mf*, *pppp*, *p*, *ppp*, and *p*. A large bracket at the top spans the entire system, with the annotation "(RALL.) e sim." written above it. The notation includes many accidentals and complex rhythmic figures.

(10)

Handwritten musical score for the second system. It features a 7/4 time signature, indicated by a circled "7" and a "4" below the staff. The notation is less dense than the first system, with several measures containing rests. Dynamic markings include *f*, *ppp*, *p*, *mf*, *f*, *ff*, *ff*, *f*, *mf*, and *p*. There are also markings for "8" above the staff and "5=4" below the staff, indicating specific rhythmic intervals or groupings.

Handwritten musical score for the third system. It features a 6/8 time signature, indicated by a circled "6" and an "8" below the staff. The notation is highly complex, with many accidentals and rhythmic markings. Dynamic markings include *pp*, *mf*, and *pp*. There are also markings for "3=2" and "9=8" below the staff, indicating specific rhythmic intervals or groupings. A large bracket at the bottom spans the entire system.

Handwritten musical score system 1, starting with a treble clef and a key signature of two sharps (F# and C#). The system contains two staves. The upper staff features complex rhythmic patterns with various accidentals and dynamic markings including *pp*, *ff*, *mf*, and *sfz*. A '(LOCO)' marking is present. The lower staff provides harmonic support with chords and bass lines. Brackets indicate time intervals such as 5:4, 7:8, and 3:2. A circled '8' is at the beginning of the system.

Handwritten musical score system 2, continuing from the previous system. It features two staves with complex rhythmic notation and dynamic markings like *pp*, *mf*, and *ff*. A '(LOCO)' marking is present in the lower staff. Brackets indicate time intervals such as 5:4, 9:8, 3:2, and 7:8. A circled '8' is at the beginning of the system. A circled '3p' with a dashed arrow is at the end of the system.

Handwritten musical score system 3, continuing from the previous system. It features two staves with complex rhythmic notation and dynamic markings like *pp*. A circled '3p' with a dashed arrow is at the beginning of the system. The system concludes with a thick vertical bar and the word 'ATTACCA!' written in large, bold letters.

3p

[NO PED]



# PHOTING BIRDS

$\text{♩} = 60$  (OR FASTER) SLIGHTLY ALOOF, COOL

(3P) (MINIMAL PEDAL)

MORE EXPRESSIVE

Handwritten musical score for the first system. It consists of two staves. The upper staff is in treble clef and contains a melodic line with various accidentals (sharps, flats, naturals) and slurs. The lower staff is in bass clef and contains a bass line with fewer notes. Dynamics include *p*, *mf*, and *f*. A 5:4 ratio is indicated above the upper staff. A vertical bar line is present in the middle of the system.

Handwritten musical score for the second system. It consists of two staves. The upper staff is in treble clef and contains a melodic line with various accidentals and slurs. The lower staff is in bass clef and contains a bass line. Dynamics include *(p)*, *(mf)*, *f*, *mf*, *ff*, and *(ff)*. A 5:4 ratio and a 3:2 ratio are indicated above the upper staff. The word "WARMLY" is written in capital letters above the right side of the system. A vertical bar line is present in the middle of the system.

Handwritten musical score for the third system. It consists of two staves. The upper staff is in treble clef and contains a melodic line with various accidentals and slurs. The lower staff is in bass clef and contains a bass line. Dynamics include *f*, *pp*, *f*, *p*, *mf*, and *(f)*. A 5:4 ratio and a 3:1 ratio are indicated above the upper staff. A vertical bar line is present in the middle of the system.

Handwritten musical score system 1. It consists of two staves. The upper staff is in treble clef and contains a melodic line with various accidentals (sharps, flats, naturals) and dynamic markings such as *f*, *ff*, and *p*. A bracket above the staff indicates a 3:2 ratio. The lower staff is in bass clef and contains a bass line with dynamic markings *f* and *ff*. A 5:4 ratio is marked at the end of the system.

Handwritten musical score system 2. It consists of two staves. The upper staff is in treble clef and contains a melodic line with various accidentals and dynamic markings such as *f*, *p*, and *(f)*. A bracket above the staff indicates a 3:2 ratio. The lower staff is in bass clef and contains a bass line with dynamic markings *f* and *(f)*.

Handwritten musical score system 3. It consists of two staves. The upper staff is in treble clef and contains a melodic line with various accidentals and dynamic markings such as *f*, *ff*, *p*, and *(f)*. A bracket above the staff indicates a 5:4 ratio. The lower staff is in bass clef and contains a bass line with dynamic markings *ff*, */mf*, and *fff*. The text "BECOMING UNSTABLE" is written above the right side of the system.

Handwritten musical score for the first system, consisting of three staves. The top staff is in treble clef, starting with a measure marked '8'. It contains a melodic line with various accidentals and dynamics, including *ff* and *(ff)*. The middle staff is in alto clef, with a melodic line and some rhythmic markings such as  $5:4$  and  $5:4$ . The bottom staff is in bass clef, with a bass line and dynamics like *mf* and *f*. A  $9:8$  marking is present in the lower right of the system.

Handwritten musical score for the second system, also consisting of three staves. The top staff is in treble clef, starting with a measure marked '8'. It features a melodic line with dynamics such as *ff*, *pp*, and *(f)*. The middle staff is in alto clef, with a melodic line and dynamics like *mf* and *p*. The bottom staff is in bass clef, with a bass line and dynamics including *f* and *(f)*. Rhythmic markings such as  $3$ ,  $7:6$ , and  $5:6$  are visible above the middle staff.

Handwritten musical score for the first system, consisting of three staves. The top staff is in treble clef and contains a melodic line with various accidentals and dynamics, starting with  $f/pp$ . The middle staff is in treble clef and features a dense texture of notes with some rests and dynamics like  $(pp)$ ,  $f/pp$ , and  $mf$ . The bottom staff is in bass clef and contains a few notes with dynamics like  $mf$ . There are several slurs and dynamic hairpins throughout. A  $5:4$  ratio is indicated under the first staff, and a  $7:6$  ratio is indicated under the middle staff. A triplet of notes is marked with '3' above it.

Handwritten musical score for the second system, consisting of three staves. The top staff is in treble clef and contains a melodic line with dynamics like  $fz$  and  $pp$ . The middle staff is in treble clef and features a dense texture of notes with dynamics like  $(mf)$ ,  $ff$ , and  $mf$ . The bottom staff is in bass clef and contains a few notes with dynamics like  $mfz$  and  $ff$ . There are several slurs and dynamic hairpins throughout. A  $5:4$  ratio is indicated under the first staff, and a  $7:6$  ratio is indicated under the middle staff. A  $11:8$  ratio is indicated under the middle staff. A triplet of notes is marked with '3' above it.

Handwritten musical score for the first system, consisting of three staves. The top staff is in treble clef and begins with a circled '8' and a dynamic marking 'f'. It contains a complex melodic line with many accidentals and slurs. The middle staff is in bass clef and features a bass line with several slurs and dynamic markings, including 'f' and 'ff'. The bottom staff is in bass clef and shows a guitar-style notation with fret numbers and a 'fz' marking. Rhythmic annotations include '3:2', '5:4', '7:8', and '3:2' with brackets. A 'Loco' marking is present at the end of the system.

Handwritten musical score for the second system, continuing the notation from the first system. It consists of three staves. The top staff is in treble clef and starts with a circled '8' and a '(Loco)' marking. The middle staff is in bass clef and includes a 'mf' dynamic marking. The bottom staff is in bass clef and features a 'fz' marking and a '(Bb)' dynamic marking. The notation continues with complex melodic and bass lines, including slurs and accidentals.

Handwritten musical score for the first system. It consists of three staves: a treble staff, a middle staff, and a bass staff. The treble staff contains a complex melodic line with many accidentals and slurs, with a  $5:4$  ratio indicated above it. The middle staff has a bass line with dynamic markings  $ff$ ,  $f$ , and  $mf$ , and includes the instruction "Loco". The bass staff has a few notes with a  $3:2$  ratio and a  $5:6$  ratio. A  $3:2$  ratio is also written above the middle staff. The system ends with a circled  $p$  marking.

$\downarrow = 96$  SMOOTHLY, WAVELIKE

Handwritten musical score for the second system. It consists of three staves: a treble staff, a middle staff, and a bass staff. The treble staff has a melodic line with a  $7:6$  ratio and a  $7:6$  ratio above it. The middle staff has a complex rhythmic pattern with a  $7:6$  ratio. The bass staff has a bass line with dynamic markings  $p$ ,  $ff$ ,  $pp$ , and  $mf$ . There are performance instructions: "(Ah)" in the bass staff, "(PED)" at the bottom, and a box containing "UPWARDS: SLIGHTLY" and "DOWNWARDS: SLIGHTLY" with arrows. A "(LH) →" instruction is also present.

LIKE STELLAR BIRDS

Handwritten musical score for the first system. The top staff is in treble clef with a key signature of one sharp (F#). It begins with a dynamic marking of *sfz* and contains several slurs and accents. The bottom staff is in bass clef with a key signature of one sharp (F#) and a dynamic marking of *pp*. It features a complex rhythmic pattern with many sixteenth notes and includes slurs, accents, and dynamic markings such as *pp*, *mfz*, and *pp*. Rhythmic annotations include  $3:2$ ,  $5:4$ , and  $3:2$ .

Handwritten musical score for the second system. The top staff is in treble clef with a key signature of one sharp (F#). It starts with a dynamic marking of *sfz* and includes slurs and accents. The bottom staff is in bass clef with a key signature of one sharp (F#) and a dynamic marking of *pp*. It contains a complex rhythmic pattern with many sixteenth notes and includes slurs, accents, and dynamic markings such as *pp*, *mfz*, and *pp*. Rhythmic annotations include  $3:2$ ,  $5:4$ , and  $3:2$ .

Handwritten musical score for the third system. The top staff is in treble clef with a key signature of one sharp (F#). It begins with a dynamic marking of *pp* and includes slurs and accents. The bottom staff is in bass clef with a key signature of one sharp (F#) and a dynamic marking of *pp*. It features a complex rhythmic pattern with many sixteenth notes and includes slurs, accents, and dynamic markings such as *pp*, *pp*, and *pp*. A section of the bottom staff is marked "(cloudy)" and "(Sim.)". Rhythmic annotations include  $3:2$  and  $3:2$ .



Handwritten musical score for the first system. The treble clef staff contains a melodic line with notes and rests, marked with dynamics *sfz*, *p*, and *sfz/p*. A slur covers the first part of the melody. Interval ratios  $5:4$  and  $3:2$  are indicated below the staff. The bass clef staff features a complex, rhythmic accompaniment with many notes. A  $7:6$  interval is marked at the end of the system.

Handwritten musical score for the second system. The treble clef staff continues the melodic line, marked with *mf* and *(mf)*. A *(CLOUDY)* annotation is written in the treble staff. The bass clef staff continues the rhythmic accompaniment. A  $3$  (triple) marking is visible in the treble staff.

Handwritten musical score for the third system. The treble clef staff concludes the melodic line, marked with *(sfz)* and *mf*. Interval ratios  $7:6$ ,  $5:6$ ,  $3:2$ , and  $7:6$  are indicated below the staff. The bass clef staff concludes the rhythmic accompaniment. A  $3$  (triple) marking is visible in the treble staff.

Handwritten musical score for the first system. It consists of three staves: a treble clef staff at the top, a bass clef staff in the middle, and a lower bass clef staff at the bottom. The top staff begins with a dynamic marking of *mf* and a *p* hairpin. A bracket below it indicates a duration of 5:6. The middle staff contains a section labeled *(CLOUDY)*. The bottom staff starts with a dynamic marking of *(pp)* and a circled '8'. The system concludes with a treble clef staff marked *mf* and a bass clef staff with a circled '8'. Brackets below the bottom staff indicate durations of 5:4 and 7:8.

Handwritten musical score for the second system. It consists of three staves: a treble clef staff at the top, a bass clef staff in the middle, and a lower bass clef staff at the bottom. The top staff features several notes with accents and dynamic markings: *sfz* (E4), *sfz*, *sfz* (E4), and *sfz/mf*. The middle staff has dynamic markings of *mf* and *mf*. The bottom staff starts with a dynamic marking of *(pp)*. The system concludes with a diagonal line. Brackets below the middle staff indicate durations of 7:8, 5:4, 9:8, 5:4, and 7:8.

$\text{♩} = 60$

Handwritten musical score for the first system, featuring three staves. The top staff is marked with **ACCEL.** and dynamic markings *mf*, *mfz*, *fz*, *f*, and *(ff)*. It includes a **(LOUDY)** annotation and a measure marked **7.** with a  $9=10$  bracket. The middle staff starts with *(pp)* and contains a complex melodic line with a  $5=4$  bracket. The bottom staff begins with *ppp* and includes a **(Laco)** marking. A vertical bar line is present at the end of the system.

Handwritten musical score for the second system, also with three staves. The top staff features a  $5=4$  bracket and a  $3-3$  bracket. The middle staff has a  $9=8$  bracket and a **(p)** marking. The bottom staff includes dynamic markings *mf*, *pp*, and *(poco)*, along with a  $7=6$  bracket and a **(sfz)** marking. The system concludes with a  $5=4$  bracket and a **(p)** marking.

Handwritten musical score for the first system. It consists of three staves: a treble staff at the top, a middle treble staff, and a bass staff at the bottom. The top treble staff contains a melodic line with a large slur over the right half. Above this staff are rhythmic markings: a 3-measure group, an 11-measure group, and another 3-measure group. The middle treble staff has a melodic line with various accidentals and dynamics like *mf* and *pp*. The bass staff features a complex rhythmic pattern with a *sfz* marking and a *pp* to *mf* dynamic range. A guitar chord diagram is shown in the lower left of the bass staff, with a *(B4)* label. The right side of the system shows a *pp* to *ff* dynamic range and a 7-measure group.

Handwritten musical score for the second system. It consists of three staves: a treble staff at the top, a middle treble staff, and a bass staff at the bottom. The top treble staff has a melodic line with a slur and a *ff* dynamic marking. Above it are rhythmic markings for 5-measure and 7-measure groups. The middle treble staff continues the melodic line with a *mf* dynamic and a *fz (poco)* marking. The bass staff has a complex rhythmic pattern with a *mfz* marking and a *sfz* marking. A guitar chord diagram is shown in the lower left of the bass staff. The right side of the system shows a *ff* dynamic and a 5-measure group.

Handwritten musical score for the first system, consisting of three staves. The top staff is in treble clef with a key signature of one sharp (F#) and a time signature of 7/8. It features a complex melodic line with many accidentals and a bracketed section of six notes labeled "7=6". The middle staff is in bass clef and contains a bass line with dynamic markings "ff" and "f". The bottom staff is a guitar-like staff with fretboard diagrams and dynamic markings "ff" and "sfz". A slur covers the right side of the system, with a bracketed section of eight notes labeled "11=8".

Handwritten musical score for the second system, continuing the notation from the first system. It consists of three staves. The top staff has a melodic line with a slur and a bracketed section of four notes labeled "5=4". The middle staff contains a bass line with dynamic markings "fff", "p", "ff", and "pp". The bottom staff is a guitar-like staff with fretboard diagrams and dynamic markings "pp", "ppp", and "(B)".

Handwritten musical score for the first system, consisting of three staves. The top staff begins with a treble clef and a common time signature, marked with a circled '8'. It contains a series of rhythmic patterns, including a triplet of eighth notes and a group of sixteenth notes. The middle staff starts with a treble clef and a circled '9', followed by a common time signature. It features a series of notes with a dynamic marking of *p* and a bracketed section of sixteenth notes. The bottom staff begins with a bass clef and a common time signature, showing a series of notes with a dynamic marking of *p*. The system includes various dynamic markings such as *pp*, *p*, *mf*, *ff*, and *fff*. Rhythmic annotations include *5:4*, *9:8*, and *3*. A large slur covers the top two staves, and a smaller slur is present on the bottom staff.

Handwritten musical score for the second system, consisting of three staves. The top staff begins with a treble clef and a common time signature, marked with a circled '8'. It contains a series of rhythmic patterns, including a triplet of eighth notes and a group of sixteenth notes. The middle staff starts with a treble clef and a circled '9', followed by a common time signature. It features a series of notes with a dynamic marking of *pp* and a bracketed section of sixteenth notes. The bottom staff begins with a bass clef and a common time signature, showing a series of notes with a dynamic marking of *f*. The system includes various dynamic markings such as *pp*, *f*, *fff*, and *ffff*. Rhythmic annotations include *5:4* and *(MOLTO)*. A large slur covers the top two staves, and a smaller slur is present on the bottom staff.

mf p pp ppp

(STACCATO) 96 (LIKE WHITEOUT) (LEGATO)

8

7-8 3-2 7-8 5-4

ff f sfz

(PED)

Handwritten musical score for the first system. It consists of two staves: a piano staff (top) and a bass staff (bottom). The piano staff begins with a treble clef, a key signature of two flats, and a dynamic marking of  $(ff)$ . The bass staff begins with a bass clef and a dynamic marking of  $(f)$ . The score is filled with complex rhythmic patterns, including sixteenth and thirty-second notes, and rests. There are several dynamic markings:  $ff$ ,  $sfz$ , and  $sfz$ . A tempo change is indicated by  $9:8$  and  $5:6$  ratios. A  $(PED)$  marking is present at the beginning. A large slur covers the entire system.

$(PED)$   $\wedge sfz$   $RIT.$   $\wedge sfz$   $A TEMPO$   $\wedge sfz$

Handwritten musical score for the second system. It consists of two staves: a piano staff (top) and a bass staff (bottom). The piano staff begins with a treble clef, a key signature of two flats, and a dynamic marking of  $(f)$ . The bass staff begins with a bass clef and a dynamic marking of  $(f)$ . The score includes a section marked  $(Loco)$  with a  $5:4$  ratio. There are several dynamic markings:  $f$ ,  $mf$ ,  $ff$ , and  $(p)$ . A tempo change is indicated by  $x4$ . A  $(PED)$  marking is present at the beginning. A large slur covers the entire system.

$(PED)$   $\wedge sfz$   $\wedge sfz$   $(B4)$



SLOWER, GENTLY

The image shows a handwritten musical score for piano, consisting of three staves and a separate line for the left pedal. The score is written in treble clef with a key signature of one sharp (F#). The tempo and mood are indicated as "SLOWER, GENTLY".

**Staff 1 (Right Hand):** Features a melodic line with a 7:8 ratio bracket over a sequence of notes. It includes dynamic markings such as *sfz* and *pp*, and a slur over a later section with a 5:6 ratio bracket.

**Staff 2 (Left Hand):** Provides harmonic accompaniment with chords and single notes. It includes dynamic markings like *p* and *mf*.

**Staff 3 (Pedal):** Shows the left pedal line with markings for *(PED)* and *sfz*.

**Annotations:** The score includes various performance instructions such as *sfz*, *pp*, *p*, and *mf*. A handwritten note "(ATTACCA GALLERY OF SPACES)" is written in the right margin. The piece concludes with a double bar line.

# GALLERY OF SPACES

$\downarrow = 42$  WITH QUIET DELIBERATION

The musical score is written on three systems of staves, each with a treble and bass clef. The notation is highly detailed, featuring numerous accidentals (sharps, flats, naturals) and complex rhythmic markings. Above the staves, various time signatures and ratios are indicated, such as 5:4, 3:2, 7:8, 9:8, 7:6, and 3:4. Some measures are marked with 'pp' (pianissimo) or 'p' (piano). The score includes many slurs, ties, and dynamic markings, suggesting a piece of music with intricate phrasing and a focus on timbre and rhythm. The overall style is that of a composer's sketch or a highly detailed manuscript.

momentary

42

Handwritten musical score for the first system. It consists of two staves with complex rhythmic patterns. Above the staves, several time signature changes are indicated:  $3=2$ ,  $5=4$ ,  $9=8$ ,  $7=8$ ,  $5=4$ , and  $7=6$ . Below the staves, more time signature changes are noted:  $7=8$ ,  $9=8$ ,  $3=2$ ,  $9=8$ ,  $7=8$ ,  $5=4$ ,  $3$ ,  $5=4$ ,  $3=2$ ,  $9=8$ ,  $5=4$ , and  $3=2$ . The music includes various notes, rests, and accidentals. A dynamic marking  $(ppp)$  is present at the end of the system.

Handwritten musical score for the second system. It consists of two staves. Above the staves, time signature changes are indicated:  $5=4$ ,  $5=4$ ,  $3=2$ , and  $9=8$ . Below the staves, more time signature changes are noted:  $5=4$ ,  $7=8$ ,  $5=4$ ,  $5=6$ , and  $5=4$ . The music includes various notes, rests, and accidentals. Dynamic markings  $pp$  and  $ppp$  are present. A dynamic marking  $(pp)$  is also present at the end of the system.

Handwritten musical score for the third system. It consists of two staves. Above the staves, time signature changes are indicated:  $5=4$ ,  $5=4$ , and  $3$ . Below the staves, more time signature changes are noted:  $3$ ,  $5=4$ , and  $5=4$ . The music includes various notes, rests, and accidentals. Dynamic markings  $mf$ ,  $p$ , and  $pp$  are present. A dynamic marking  $(pp)$  is also present at the end of the system.

This page contains three systems of handwritten musical notation, likely for a piano or similar instrument. The notation is dense and includes various rhythmic and dynamic markings.

- System 1:** Features a treble clef and a key signature of one sharp (F#). It includes a tempo marking of  $\text{♩} = 18$  and a dynamic marking of  $mf$ . Rhythmic markings include  $5:4$ ,  $7:8$ ,  $9:8$ , and  $5:6$ . There are also markings for  $ppp$  and  $pp$ .
- System 2:** Continues the notation with a variety of rhythmic patterns. It includes dynamic markings such as  $pp$ ,  $(pp)$ , and  $f$ . Rhythmic markings include  $9:8$ ,  $5:4$ ,  $3:2$ , and  $7:8$ .
- System 3:** The final system on the page, featuring complex rhythmic structures. It includes dynamic markings like  $(pp)$  and  $pp$ . Rhythmic markings include  $5:4$ ,  $9:8$ ,  $3:2$ , and  $7:8$ .

The notation is characterized by frequent use of slurs, beams, and complex rhythmic groupings, suggesting a highly technical and expressive piece of music.

Handwritten musical score for the first system. It consists of two staves. The upper staff is in treble clef and the lower in bass clef. The music is characterized by complex rhythmic patterns with various time signatures and ratios indicated above the notes, such as 9:8, 7:8, 3:2, 3, 5:4, and 5:4. Dynamic markings include *pp*, *mf*, and *p*. There are also performance instructions like  $\text{tr}$  and  $\text{rit}$ . A large vertical bar is present in the middle of the system.

Handwritten musical score for the second system, continuing from the first. It also consists of two staves. The notation includes complex rhythmic patterns with ratios like 2:8, 9:8, 3:2, 5:4, and 9:8. Dynamic markings include *mf*, *p*, and *pp*. Performance instructions like  $\text{tr}$  and  $\text{rit}$  are present. A *ped* marking is visible at the beginning of the system.

Handwritten musical score for the third system. It consists of two staves. The notation includes complex rhythmic patterns with ratios like 5:4, 3, 5:4, 3:2, 5:4, and 5:4. Dynamic markings include *mf*, *f*, *pp*, and *ppp*. Performance instructions like  $\text{tr}$  and  $\text{rit}$  are present. A *ped* marking is visible at the beginning of the system.

Handwritten musical score for the first system. The top staff is in treble clef and the bottom staff is in bass clef. The music is marked with various dynamics including *p*, *mf*, and *pp*. Rhythmic markings include  $5:4$  and  $7:8$ . There are several accidentals (flats and naturals) and a fermata over a note in the top staff. A *(PED)* marking is present in the bass staff.

Handwritten musical score for the second system. It continues the piece with complex rhythmic patterns. Dynamics range from *pp* to *mf*. Rhythmic markings include  $5:4$ ,  $7:8$ , and  $9:8$ . A *(Loco)* marking is present in the top staff. A *(PED)* marking is present in the bass staff.

Handwritten musical score for the third system. The music continues with complex rhythmic patterns. Dynamics include *p*, *mf*, and *pp*. Rhythmic markings include  $3:2$ ,  $5:4$ , and  $7:8$ . A *(PED)* marking is present in the bass staff.

\* CROTCHET = 72

46

# II UNFORTHCOMINGLY

(COUNT THROUGH)

5:4 3:2 3:2  $\downarrow = 54$

(f) pp p

(PED) (PED) (PED)

(PED) (PED)

(PED) mf poco mf

$\text{♩} = 112$

Handwritten musical score for the first system, consisting of two staves. The music is written in treble clef with a key signature of one flat. It features complex rhythmic patterns with various time signatures and ratios such as 5:4, 7:8, and 9:8. Dynamic markings include *ppp*, *p*, and *mf*. Performance instructions include *Loco* and *(PED)*. A circled 'C' is present below the second staff. The system concludes with a right-pointing arrow.

Handwritten musical score for the second system, consisting of two staves. It continues the complex rhythmic and dynamic notation from the first system. Time signatures and ratios include 3:2, 5:4, 7:8, and 3:2. Dynamic markings include *mf*, *ppp*, and *pp*. Performance instructions include *(PED)*. The system concludes with a right-pointing arrow.

Handwritten musical score for the third system, consisting of two staves. It shows further development of the musical material with complex rhythmic patterns and dynamic markings. Time signatures and ratios include 5:4 and 7:8. Dynamic markings include *mf*, *pp*, and *ppp*. Performance instructions include *(PED)*. The system concludes with a right-pointing arrow.



Handwritten musical score for the first system. It consists of two staves. The top staff has a treble clef and the bottom staff has a bass clef. The music is written in a complex, non-standard rhythmic style. Above the staves, there are several time signature changes:  $3:2$ ,  $5:4$ ,  $6:4$ , and  $3:2$ . Dynamic markings include  $pp$ ,  $f$  (poco), and  $mf$  (poco). There are also markings for  $E_2$  and  $C_2$ . A large bracket above the first part of the system is labeled  $3:2$ . A  $(PED)$  marking is present at the beginning and end of the system.

Handwritten musical score for the second system. It consists of two staves. The top staff has a treble clef and the bottom staff has a bass clef. The music continues with complex rhythmic patterns. Time signature changes include  $9:8$ ,  $5:6$ ,  $7:6$ ,  $3:2$ ,  $3$ , and  $5:4$ . Dynamic markings include  $pp$  and  $ppp$ . A large bracket above the first part of the system is labeled  $9:8$ . A  $(PED)$  marking is present at the beginning and end of the system.

Handwritten musical score for the third system. It consists of two staves. The top staff has a treble clef and the bottom staff has a bass clef. The music concludes with complex rhythmic patterns. Time signature changes include  $3:2$ ,  $3:2$ ,  $7:8$ ,  $3:2$ ,  $9:8$ ,  $7:6$ ,  $9:8$ ,  $5:4$ ,  $3$ , and  $9:8$ . Dynamic markings include  $ppp$ ,  $pp$ , and  $ppp$  (poco). A large bracket above the first part of the system is labeled  $3:2$ . A  $(PED)$  marking is present at the beginning and end of the system.

Handwritten musical score for the first system. It consists of a treble staff and a bass staff. The treble staff begins with a  $9:8$  time signature, followed by another  $9:8$ . The bass staff starts with a  $5:4$  time signature, then changes to  $3:2$ ,  $5:4$ ,  $5:4$ , and finally  $3:2$ . Dynamic markings include  $pp$  and  $PPP$ . A circled number  $30$  is placed below the bass staff. A dashed line labeled  $(PED)$  spans across the bottom of the system.

Handwritten musical score for the second system. It features a treble staff and a bass staff. The treble staff has a  $7:8$  time signature. A section is marked  $♩ = 48$  and  $(PESANTE)$ . The dynamic marking  $PPP$  is present. A circled number  $30$  is at the beginning of the system. A dashed line labeled  $(PED)$  is at the bottom.

Handwritten musical score for the third system. It includes a treble staff and a bass staff. The treble staff has  $3:2$  and  $3$  markings. The bass staff has  $7:8$ ,  $5:4$ ,  $5:4$ , and  $5:4$  time signatures. Dynamic markings include  $pp$  and  $p$ . A circled number  $30$  is at the start. A dashed line labeled  $(PED)$  is at the bottom.

Handwritten musical score for the first system. It consists of two staves (treble and bass clef) with a grand staff below. The music is marked with dynamics *mf* and *p*. Time signatures  $5:4$ ,  $3$ ,  $3:2$ ,  $7:6$ , and  $9:8$  are indicated above the notes. A *(p)* marking is present in the first measure. A *(PED)* marking is at the bottom left. The system ends with a repeat sign.

Handwritten musical score for the second system. It consists of two staves with a grand staff below. The music is marked with dynamics *mf* and *pp*. Time signatures  $3:2$ ,  $7:8$ ,  $5:4$ , and  $7:6$  are indicated. A section is marked *(Loco)* with a thick vertical bar. A *(RH)* marking is present. A *(PED)* marking is at the bottom left. The system ends with a repeat sign.

Handwritten musical score for the third system, titled "III ASPIRINGLY". It consists of two staves with a grand staff below. The tempo is marked  $\text{♩} = 112$ . The music is marked with dynamics *pp*, *ppp*, *f*, and *ff*. Time signatures  $7:8$ ,  $5:6$ ,  $3:2$ ,  $5:6$ ,  $9:8$ , and  $5:4$  are indicated. A *(UC)* marking is in a circle at the bottom left. A *(GRADUAL RELEASE)* marking is below the first staff. A *(PED)* marking is at the bottom left. A *(f)* marking is at the bottom right. The system ends with a repeat sign.

$\downarrow = 48$

$\downarrow = 46$

(ff)

(PED)

5:6, 3:2, 3:2, 7:8, 8 (G#), 3:2, 5:6, 3:2

mf, pp, p, ppp

(laco)

mf, f, pp, f, f

3:2, 3:2, 3:2, 3:2, 3:2

(PED)

$\downarrow = 54$

(GENTLY)

(fff)

9:8, 3:2, 9:8, 9:8, 3:2, 7:8, 3:2, 5:4, 7:8, 3

mf, f, pp, f, pp, ppp

(PED)

Handwritten musical score for the first system. It consists of two staves. The upper staff has a treble clef and contains complex rhythmic patterns with various note values and rests. Above the staff, there are several bracketed measures with time signatures:  $5:4$ ,  $3:2$ ,  $5:4$ , and  $5:4$ . The lower staff has a bass clef and contains similar rhythmic patterns. Below the lower staff, there are more bracketed measures with time signatures:  $5:4$ ,  $5:4$ , and  $5:4$ . Dynamic markings include  $p$  and  $mf$ . There are also some handwritten annotations like  $7.$  and  $(7.)$ .

(PED)

Handwritten musical score for the second system. It consists of two staves. The upper staff has a treble clef and contains complex rhythmic patterns. Above the staff, there are several bracketed measures with time signatures:  $5:4$ ,  $3:2$ ,  $5:6$ ,  $3:2$ , and  $7:8$ . The lower staff has a bass clef and contains similar rhythmic patterns. Below the lower staff, there are more bracketed measures with time signatures:  $9:8$ ,  $9:8$ , and  $7:8$ . Dynamic markings include  $sfz$ ,  $pp$ , and  $mf$ . There are also some handwritten annotations like  $7.$  and  $pp$ .

(PED)

Handwritten musical score for the third system. It consists of two staves. The upper staff has a treble clef and contains complex rhythmic patterns. Above the staff, there are several bracketed measures with time signatures:  $3:2$ ,  $3:2$ , and  $5:4$ . The lower staff has a bass clef and contains similar rhythmic patterns. Below the lower staff, there are more bracketed measures with time signatures:  $3:2$ ,  $3:2$ , and  $5:4$ . Dynamic markings include  $fff$ ,  $pp$ ,  $loco$ , and  $f$  (poco). There are also some handwritten annotations like  $(D4)$ ,  $pp$ , and  $f$  (poco).

Handwritten musical score for three systems of staves. The notation includes complex rhythmic patterns with various time signatures and rests, dynamic markings, and performance instructions.

**System 1:** Features a treble clef staff with a  $7/8$  time signature. Dynamic markings include  $mf$  and  $pp$ . Rhythmic markings include  $7/8$ ,  $3/2$ , and  $2/8$ . A  $9/8$  time signature is also present.

**System 2:** Features a treble clef staff with a  $7/8$  time signature. Dynamic markings include  $mf$ ,  $pp$ , and  $p$ . Rhythmic markings include  $9/8$ ,  $7/8$ ,  $5/4$ , and  $3/2$ . A  $5/6$  time signature is also present. Performance instructions include  $(PED)$ ,  $(A)$ , and  $(B)$ .

**System 3:** Features a treble clef staff with a  $7/8$  time signature. Dynamic markings include  $mfz$ ,  $p$ ,  $mf$ , and  $fz/mf$ . Rhythmic markings include  $7/8$ ,  $5/4$ ,  $3/2$ , and  $7/8$ . Performance instructions include  $(PED)$  and  $loco$ .

**Footnote:** \*CROTCHET =  $7/2$

Handwritten musical score for the first system. It consists of a piano staff (top) and a bass staff (bottom). The piano staff begins with a treble clef and a key signature of one sharp (F#). The bass staff begins with a bass clef and a key signature of one flat (Bb). The music is marked with various dynamics: *mf* (mezzo-forte), *f* (forte), *ff* (fortissimo), and *p* (piano). Rhythmic patterns are indicated with time signatures such as 5:4, 7:8, 9:8, and 3:2. A fermata is present over a note in the piano staff. The system concludes with a double bar line and an arrow pointing to the right.

(PED) **IV INTENSELY EXPRESSIVE** ♩ = 18

Handwritten musical score for the second system. It continues from the first system with piano and bass staves. The piano staff includes a circled '8' and a 'Loco' marking. Dynamics include *mf*, *f*, *ff*, and *(mf)*. Rhythmic patterns are marked with 5:4, 7:8, 9:8, 3:2, and 5:6. A double bar line is used to separate the two systems. The system ends with an arrow pointing right.

Handwritten musical score for the third system. It continues with piano and bass staves. Dynamics include *mf*, *ff*, and *fff*. Rhythmic patterns are marked with 5:4, 7:8, 3:2, 9:8, and 7:6. The system concludes with a double bar line and an arrow pointing right.

(PED)

Handwritten musical score system 1. It features two staves with complex rhythmic patterns. Above the staves, there are several bracketed time signatures:  $5:4$ ,  $9:8$ ,  $5:6$ ,  $3:2$ ,  $5:4$ , and  $5:4$ . A tempo marking  $\text{♩} = 46$  is present at the top center. The music includes dynamic markings such as  $ff$  and  $ff$ . A vertical bar line is present in the middle of the system. The bottom staff has a circled  $8$  and a circled  $8$  below it. The system ends with a circled  $8$  and a circled  $8$  below the staff, and a circled  $8$  below the staff.

Handwritten musical score system 2. It features two staves with complex rhythmic patterns. Above the staves, there are several bracketed time signatures:  $9:8$ ,  $5:4$ ,  $7:8$ ,  $3:2$ , and  $5:4$ . Below the staves, there are several bracketed time signatures:  $5:6$ ,  $5:4$ ,  $5:6$ ,  $7:8$ ,  $9:8$ , and  $5:4$ . The system starts with a circled  $8$  and a circled  $8$  below the staff. The system ends with a circled  $8$  and a circled  $8$  below the staff.

Handwritten musical score system 3. It features two staves with complex rhythmic patterns. Above the staves, there are several bracketed time signatures:  $7:8$ ,  $9:8$ ,  $7:6$ ,  $7:8$ ,  $5:4$ ,  $5:4$ ,  $7:6$ ,  $5:4$ ,  $5:4$ ,  $9:8$ ,  $5:6$ ,  $9:8$ , and  $3:2$ . Below the staves, there are several bracketed time signatures:  $7:8$ ,  $5:4$ ,  $5:6$ ,  $3:2$ ,  $5:4$ ,  $9:8$ ,  $5:6$ ,  $9:8$ , and  $3:2$ . The system starts with a circled  $8$  and a circled  $8$  below the staff. The system ends with a circled  $8$  and a circled  $8$  below the staff.



POCO RALL.

$\text{♩} = 54$  EXPRESSIVELY — FORLORN, AGITATED

56

Handwritten musical score for the first system, measures 56-60. It features a treble and bass clef with complex rhythmic patterns and accidentals. A fermata is placed over the end of measure 60. Performance markings include *mfz*, *pp*, and *p*. Rhythmic ratios like 9:8, 5:6, 5:4, and 7:8 are indicated with brackets. A circled "3p" is followed by "(PEDAL FOR LEGATO)" with a dashed arrow pointing right.

Handwritten musical score for the second system, measures 61-65. It continues the complex rhythmic patterns. Performance markings include *(pp)* and *ppp*. Rhythmic ratios like 7:6, 7:8, 9:8, and 5:4 are indicated. A circled "3p" is at the beginning of the system.

Handwritten musical score for the third system, measures 66-70. It features a treble clef and complex rhythmic patterns. Performance markings include *mfz* and *pp*. A circled "3p" is at the beginning. A note in the bass clef has "(LH SUSTAIN Gb THROUGH)" written below it. A dashed arrow points right from the circled "3p".

Handwritten musical score system 1, consisting of two staves. The upper staff begins with a treble clef and a key signature of two sharps (F# and C#). It contains several measures of music with notes and rests, some grouped by brackets. Dynamic markings include *pp* (pianissimo) and *mf* (mezzo-forte). Interval markings such as  $9:8$ ,  $5:4$ , and  $3:2$  are present. A circled  $3P$  is written below the first measure. The lower staff begins with a bass clef and contains notes and rests, with dynamic markings *pp* and  $9:8$ . A circled  $3P$  is written below the first measure of the lower staff.

Handwritten musical score system 2, consisting of two staves. The upper staff begins with a treble clef and a key signature of two sharps. It contains several measures of music with notes and rests, some grouped by brackets. Dynamic markings include *mf* (mezzo-forte) and *f* (forte). Interval markings such as  $9:8$ ,  $3:2$ ,  $5:4$ ,  $7:6$ , and  $7:8$  are present. A circled  $3P$  is written below the first measure. The lower staff begins with a bass clef and contains notes and rests, with dynamic markings *pp* (pianissimo) and *mf*. Interval markings such as  $9:8$  and  $3:2$  are present. A circled  $3P$  is written below the first measure. A circled  $3P$  is also written below the first measure of the upper staff.

Handwritten musical score system 3, consisting of two staves. The upper staff begins with a treble clef and a key signature of two sharps. It contains several measures of music with notes and rests, some grouped by brackets. Dynamic markings include *mf* (mezzo-forte), *p* (piano), and *f* (forte). Interval markings such as  $5:4$  and  $9:8$  are present. A circled  $3P$  is written below the first measure. The lower staff begins with a bass clef and contains notes and rests, with dynamic markings *pp* (pianissimo) and *f*. Interval markings such as  $9:8$  and  $5:4$  are present. A circled  $3P$  is written below the first measure. Below the lower staff, the text "(SUSTAIN MANVALLY)" is written, with a bracket underneath it labeled "(PED)".

Handwritten musical score for the first system. The top staff is in treble clef, and the bottom staff is in bass clef. The key signature has one sharp (F#). The time signature is 3/4. The music includes dynamic markings: *pp* and *mf*. Time signature changes are indicated: 5/4, 7/8, 3/2, and 5/4. A circled "3P" is written below the first measure.

Handwritten musical score for the second system. The top staff is in treble clef, and the bottom staff is in bass clef. The music includes dynamic markings: *pp*, *mf*, and *ppp*. Time signature changes are indicated: 9/8, 7/6, 3/2, 9/8, and 3/2. A circled "3P" is written below the second measure.

Handwritten musical score for the third system. The top staff is in treble clef, and the bottom staff is in bass clef. The system begins with the instruction "ACCEL.". The music includes dynamic markings: *(pp)*, *mf*, and *p*. Time signature changes are indicated: 9/8, 11/8, 7/6, 9/8, 5/4, 5/4, 3/2, and 7/8. A circled "3P" is written below the first measure.

SUDDENLY

Handwritten musical score for the first system. It features two staves with complex rhythmic patterns and dynamic markings. The top staff includes markings such as *mfz*, *mf*, and *ff*. The bottom staff includes *mf* and *(loco)*. Above the staves, there are several bracketed measures with time signatures:  $5:4$ ,  $7:6$ ,  $9:8$ ,  $7:6$ ,  $9:8$ , and  $5:6$ . A *(PED)* marking is present at the bottom left, and a *(bb)* marking is at the bottom right.

CANTABILE

$\downarrow = 126$

Handwritten musical score for the second system, labeled *CANTABILE*. It features two staves with complex rhythmic patterns and dynamic markings. The top staff includes markings such as *pp*, *fff*, and *f*. The bottom staff includes *mf*. Above the staves, there are several bracketed measures with time signatures:  $4:2$ ,  $9:8$ ,  $5:4$ ,  $3:2$ ,  $5:4$ ,  $3:2$ ,  $5:4$ , and  $3:2$ . A *(PED)* marking is present at the bottom left.

Handwritten musical score for the third system. It features two staves with complex rhythmic patterns and dynamic markings. The top staff includes markings such as *mf* and *pp*. The bottom staff includes *mf*. Above the staves, there are several bracketed measures with time signatures:  $5:4$ ,  $5:4$ ,  $5:4$ ,  $5:4$ ,  $5:4$ ,  $5:4$ ,  $3:2$ ,  $3:2$ ,  $7:8$ ,  $9:8$ , and  $5:4$ . A *(PED)* marking is present at the bottom left.

60

Handwritten musical score for the first system. It consists of two staves (treble and bass clef). The music is characterized by complex rhythmic patterns with various time signatures indicated by brackets above and below the notes: 3:2, 5:4, 9:8, 5:6, 7:6, 6:5, and 7. Dynamic markings include *pp*, *mf*, and *pp*. There are also some performance instructions like *pp* and *mf* with hairpins. A tempo marking  $\downarrow = 46$  V DECLINING is written at the end of the system.

Handwritten musical score for the second system. It consists of two staves. The music continues with complex rhythmic patterns and dynamic markings. Time signatures indicated include 5:4, 7, 5:4, 3:2, and 5:4. Dynamic markings include *mf*, *pp*, and *p*. A specific note is marked with *E5*. The system concludes with a *pp* marking and a *p* marking.

Handwritten musical score for the third system. It consists of two staves. The music continues with complex rhythmic patterns and dynamic markings. Time signatures indicated include 5:4, 3:2, 7, 9:8, 5:4, 5:4, 3:2, and 3:2. Dynamic markings include *ppp*, *mf*, *mfz*, and *pp*. The system concludes with a *pp* marking and a *p* marking.

$\downarrow = 54$

Handwritten musical score for the first system, consisting of two staves. The music is written in a complex, non-standard rhythmic style. The upper staff begins with a treble clef and contains several measures of music with notes beamed together. The lower staff begins with an alto clef and contains similar complex rhythmic patterns. Dynamic markings include *ppp*, *mf*, and *f*. Rhythmic ratios such as 7:6, 3:2, 7:8, and 4:3 are indicated. A vertical bar line is present in the middle of the system. The system concludes with a *(PED)* marking and a long horizontal line.

Handwritten musical score for the second system, consisting of two staves. The notation continues with complex rhythmic patterns. The upper staff has a treble clef, and the lower staff has an alto clef. Dynamic markings include *pp* and *mf*. A *(PED)* marking is present at the beginning of the system. The system concludes with a long horizontal line.

Handwritten musical score for the third system, consisting of two staves. The notation is highly complex, featuring intricate rhythmic structures. The upper staff has a treble clef, and the lower staff has an alto clef. Dynamic markings include *pp*, *ppp*, and *mf*. Rhythmic ratios such as 7:8, 5:6, 9:8, and 5:4 are indicated. The system concludes with a *(PED)* marking and a long horizontal line.

$\text{♩} = 112$

Handwritten musical score for the first system. It consists of two staves. The upper staff contains a complex melodic line with various rhythmic groupings, including 9:8, 7:6, 5:4, 9:8, 7:8, 3:2, and 5:4. The lower staff provides a harmonic accompaniment with similar rhythmic patterns, including 3:2 and 5:4. Dynamic markings include *pp* and *mf*. A thick vertical bar is present in the middle of the system.

Handwritten musical score for the second system. It consists of two staves. The upper staff continues the melodic line with rhythmic groupings such as 5:4, 7:8, 5:4, 9:8, 3:2, and 5:4. The lower staff features a more active accompaniment with rhythmic groupings like 5:4, 7:8, 9:8, 3:2, and 5:4. Dynamic markings include *ff*, *mf/ff*, *mf*, and *mf*. A thick vertical bar is present at the end of the system.

Handwritten musical score for the third system. It consists of two staves. The upper staff has a melodic line with rhythmic groupings like 5:4, 5:4, 5:4, and 3:2. The lower staff has a rhythmic accompaniment with groupings like 3:2, 3:2, 3:2, 5:4, and 3:2. Dynamic markings include *f*, *pp*, and *mfz*. A thick vertical bar is present at the end of the system.

(PED)

Handwritten musical score for the first system. It consists of a treble clef staff and a bass clef staff. The treble staff begins with a treble clef, a key signature of one sharp (F#), and a common time signature (C). The first few notes are marked with a dynamic of *sfz* (sforzando) and then *mf* (mezzo-forte). A slur covers the first four notes, with a  $3:2$  ratio indicated above it. The bass staff has a bass clef and a common time signature. It features several notes, some with a  $3:2$  ratio indicated above them. A large slur covers the entire system. A dashed line with the number '8' is drawn across the bottom of the system. The word "(PED)" is written at the bottom left.

$\text{♩} = 48$  SUSTAINED AND DIGNIFIED

Handwritten musical score for the second system. It consists of a treble clef staff and a bass clef staff. The treble staff begins with a circled '8' and a treble clef. The key signature has one sharp (F#) and the time signature is common time (C). The first few notes are marked with a dynamic of *ff* (fortissimo). A slur covers the first four notes, with a  $9:8$  ratio indicated above it. The bass staff has a bass clef and a common time signature. It features several notes, some with a  $5:4$  ratio indicated above them. A large slur covers the entire system. A dashed line with the number '8' is drawn across the bottom of the system. The word "(PED)" is written at the bottom left.

Handwritten musical score for the third system. It consists of a treble clef staff and a bass clef staff. The treble staff begins with a treble clef, a key signature of one sharp (F#), and a common time signature (C). The first few notes are marked with a dynamic of *f* (forte). A slur covers the first four notes, with a  $3:2$  ratio indicated above it. The bass staff has a bass clef and a common time signature. It features several notes, some with a  $3:2$  ratio indicated above them. A large slur covers the entire system. A dashed line with the number '8' is drawn across the bottom of the system. The word "(PED)" is written at the bottom left.



Handwritten musical score for the first system. It consists of two staves: a treble clef staff on top and a bass clef staff on the bottom. The treble staff begins with a forte (**ff**) dynamic marking. A bracket above the treble staff indicates a  $5:4$  ratio. The bass staff has a circled '8' and the word '(Loco)' written below it. The system concludes with a double bar line and a **ff** dynamic marking. Below the staves, there is a horizontal line with '(PED)' written underneath.

Handwritten musical score for the second system. It consists of two staves: a treble clef staff on top and a bass clef staff on the bottom. The treble staff has a circled '8' and a **ppp** dynamic marking. The bass staff has a circled '8' and a **ppp** dynamic marking. The system features a **f** dynamic marking and a **ff** dynamic marking. The system concludes with a double bar line and a **p** dynamic marking. Below the staves, there is a horizontal line with '(PED)' written underneath.

**VI SECRETE**

Handwritten musical score for the third system, titled "VI SECRETE". It consists of two staves: a treble clef staff on top and a bass clef staff on the bottom. The treble staff begins with a **p** dynamic marking and a circled '8'. The bass staff has a circled '8'. The system features a **mfz** dynamic marking and a **f** dynamic marking. A bracket above the treble staff indicates a  $5:4$  ratio. The system concludes with a double bar line and a **f** dynamic marking. Below the staves, there is a horizontal line with '(PED)' written underneath.

Handwritten musical score for the first system, consisting of two staves. The upper staff has dynamic markings  $f$  and  $ff$ . The lower staff has dynamic markings  $ff$  and  $ff$ . There are also some handwritten notes above the staves, possibly indicating fingerings or articulation.

(PED)  $mf/p$

$\downarrow = 46$  INCREASINGLY DISCONTINUOUS

Handwritten musical score for the second system, consisting of two staves. A large bracketed section is annotated with  $5:4$  ratios. To the right, there are annotations for  $3:2$  intervals. The lower staff has dynamic markings  $pp$  and  $ppp$ . The text "(PED)  $mf/p$ " is written above the first measure, and " $\downarrow = 46$  INCREASINGLY DISCONTINUOUS" is written below the first measure.

Handwritten musical score for the third system, consisting of two staves. It features a  $7 \ 5:4$  ratio annotation and a  $5:4$  ratio annotation. The lower staff has a  $pp$  dynamic marking and a "(Laco)" marking. There are also some handwritten notes and symbols throughout the system.

Handwritten musical score for piano, consisting of three systems of staves. The score includes various musical notations such as notes, rests, and dynamic markings.

**System 1:** Features a treble and bass staff. Dynamic markings include *pp*, *f (poco)*, and *ppp*. A tempo marking  $\text{♩} = 42$  is present. A bracketed section in the treble staff is marked *7:8*. Pedal markings *(PED)* are shown below the bass staff.

**System 2:** Includes the instruction "SLIGHTLY AGITATED" above the treble staff. Dynamic markings include *pp*, *f*, and *ppp*. A bracketed section in the treble staff is marked *5:4*. Pedal markings *(PED)* are shown below the bass staff.

**System 3:** Continues the musical notation with dynamic markings *pp*, *p*, and *mf*. A bracketed section in the treble staff is marked *9:8*. Pedal markings *(PED)* are shown below the bass staff.

The score is heavily annotated with ratios such as  $3:2$ ,  $5:4$ ,  $7:8$ , and  $9:8$ , which likely refer to specific intervals or rhythmic patterns. The notation includes various accidentals and articulation marks.

This page contains a handwritten musical score for piano, consisting of three systems of staves. The notation includes notes, rests, and various dynamic markings such as *mf*, *pp*, *ppp*, *f*, and *ff*. The score is heavily annotated with performance instructions, including numerous slurs, ties, and bracketed sections. Above the first system, there are several numerical ratios:  $\frac{1}{5}$ ,  $\frac{3}{2}$ , and  $\frac{4}{5}$ . Above the second system, there are ratios  $\frac{9}{8}$ ,  $\frac{3}{2}$ ,  $\frac{7}{8}$ , and  $\frac{5}{6}$ . Above the third system, there are ratios  $\frac{9}{8}$ ,  $\frac{3}{2}$ ,  $\frac{5}{4}$ ,  $\frac{7}{8}$ ,  $\frac{3}{2}$ , and  $\frac{3}{2}$ . A tempo marking  $\text{♩} = 48$  is located between the first and second systems, and  $\text{♩} = 112$  is located between the second and third systems. Pedal markings *(PED)* are present at the beginning and end of each system. The first system starts with a *(mf)* dynamic. The second system begins with a *(ppp)* dynamic. The third system starts with a *(pp)* dynamic. The score concludes with a final double bar line and a *(PED)* marking.

Handwritten musical score for the first system, consisting of two staves. The music is written in treble clef with a key signature of one sharp (F#). The score includes various rhythmic markings such as  $5:4$ ,  $3:2$ , and  $7:8$ . Dynamic markings include *ppp*, *p*, and *pp*. Pedal points are indicated by *(PED)* with horizontal lines. The system concludes with a long horizontal line and an arrow pointing to the right.

VII  $\downarrow = 48$  MYSTERIOUS & RECEDING

Handwritten musical score for the second system, consisting of two staves. The section begins with a Roman numeral **VII** and the tempo/mood instruction  $\downarrow = 48$  MYSTERIOUS & RECEDING. The music features complex rhythmic patterns with markings like  $3:2$ ,  $7:6$ ,  $7:8$ , and  $5:4$ . Dynamic markings include *f* (*poco*), *pp*, and *mf*. Pedal points are marked with *(PED)*. The system ends with a long horizontal line and an arrow pointing to the right.

Handwritten musical score for the third system, consisting of two staves. The music continues with complex rhythmic patterns and dynamic markings such as *pp*, *ppp*, *mf*, and *pp*. The key signature remains one sharp. Rhythmic markings include  $5:4$ ,  $3:2$ , and  $7:8$ . Pedal points are indicated by *(PED)*. The system concludes with a long horizontal line and an arrow pointing to the right.

Handwritten musical score for the first system. It consists of two staves. The upper staff is in treble clef and the lower in bass clef. The music is marked with  $5:4$  and  $3:2$  time signatures. Dynamics include  $pp$  and  $mf$ . There are handwritten annotations:  $(C\sharp D\flat)$  and  $(E\sharp F\sharp)$  in the upper staff, and  $(PED)$  in the lower staff. A tempo marking  $\downarrow = 72$  is present above the first measure.

Handwritten musical score for the second system. It consists of two staves. The upper staff is in treble clef and the lower in bass clef. The music is marked with  $5:4$  and  $3:2$  time signatures. Dynamics include  $mf$  and  $pp$ . A prominent marking is  $(PESANTE IN PP)$  in the upper staff. A tempo marking  $\downarrow = 72$  is present above the first measure.

Handwritten musical score for the third system. It consists of two staves. The upper staff is in treble clef and the lower in bass clef. The music is marked with  $5:4$  and  $3:2$  time signatures. Dynamics include  $ppp$  and  $pp$ . A tempo marking  $\downarrow = 42$  is present above the first measure. There are various handwritten annotations and markings throughout the system.

Handwritten musical score for the first system. The system consists of two staves: a piano staff (top) and a bass staff (bottom). The piano staff begins with a treble clef and a key signature of one sharp (F#). The bass staff begins with a bass clef and a key signature of one sharp (F#). The music is marked with various time signatures and dynamics. The piano staff has a  $5:4$  time signature, followed by  $7:6$ , and then  $5:4$ . The bass staff has a  $3:2$  time signature, followed by  $7:8$ ,  $5:4$ ,  $9:8$ , and  $5:4$ . Dynamics include *ppp* (pianissimo) and *pp* (piano). A circled note in the bass staff is labeled "(Loco)". A bracket labeled "8" spans the first two measures of the bass staff. A horizontal line with an arrow labeled "(PED)" is positioned below the staves.

Handwritten musical score for the second system. The system consists of two staves: a piano staff (top) and a bass staff (bottom). The piano staff begins with a treble clef and a key signature of one sharp (F#). The bass staff begins with a bass clef and a key signature of one sharp (F#). The music is marked with various time signatures and dynamics. The piano staff has a  $3:2$  time signature, followed by  $5:4$ ,  $7:8$ ,  $5:6$ , and  $7:8$ . The bass staff has a  $7:8$  time signature, followed by  $7:8$ ,  $3:2$ , and  $7:8$ . Dynamics include *pp* (piano) and *mfz* (mezzo-forte). A horizontal line with an arrow labeled "(PED)" is positioned below the staves.

Handwritten musical score for the third system. The system consists of two staves: a piano staff (top) and a bass staff (bottom). The piano staff begins with a treble clef and a key signature of one sharp (F#). The bass staff begins with a bass clef and a key signature of one sharp (F#). The music is marked with various time signatures and dynamics. The piano staff has a  $7:8$  time signature, followed by  $5:4$ ,  $3:2$ ,  $mfz, and  $f. The bass staff has a  $7:8$  time signature, followed by  $5:4$ ,  $3:2$ ,  $9:8$ ,  $5:4$ , and  $3:2$ . Dynamics include *pp* (piano), *mfz* (mezzo-forte), and *f* (forte). A horizontal line with an arrow labeled "(PED)" is positioned below the staves.$$

♩ = 54 SIMPLY - WITH RUBATO

Handwritten musical score for the first system, consisting of two staves. The top staff contains several measures with accents (^) and dynamic markings such as *pp* (EQUALLY), *pp*, *p*, and *pp*. Rhythmic markings include  $3:2$ ,  $7$ ,  $7:8$ , and  $9:8$ . The bottom staff features a *pp* marking and a  $3:2$  ratio. Pedal markings *(PED)* are present at the beginning and end of the system.

Handwritten musical score for the second system, consisting of two staves. The top staff includes dynamic markings *pp*, *p*, *pp*, and *ppp*, along with accents (^) and a  $5:4$  ratio. The bottom staff features a  $5:4$  ratio and a *p* marking. Pedal markings *(PED)* are used throughout the system.

Handwritten musical score for the third system, consisting of two staves. The top staff includes dynamic markings *pp*, *ppp*, and *pp*, along with accents (^) and a  $7:8$  ratio. The bottom staff features dynamic markings *p*, *mf*, *pp*, and *ppp*, along with a  $7$  marking and ratios  $9:8$ ,  $5:4$ , and  $3:2$ . Pedal markings *(PED)* are present at the beginning and end of the system.



Handwritten musical score for the first system. It consists of two staves. The top staff begins with a treble clef and contains notes with a  $5:6$  interval bracket and a  $9:8$  interval bracket. Dynamic markings include  $(ppp)$  and  $pp$ . The bottom staff begins with a bass clef and contains notes with  $5:4$  interval brackets and a  $3:2$  interval bracket. Dynamic markings include  $(ppp)$ ,  $mfz$ ,  $f$ , and  $p$ . A  $7:8$  interval bracket is also present. Pedal markings  $(PED)$  are shown below the staff with arrows indicating the pedal's duration.

Handwritten musical score for the second system. It consists of two staves. The top staff has a treble clef and notes with a  $5:4$  interval bracket and a  $3:2$  interval bracket. Dynamic markings include  $mf/p$  and  $p$ . The bottom staff has a bass clef and notes with a  $5:4$  interval bracket, a  $3:2$  interval bracket, and a  $5:4$  interval bracket. Dynamic markings include  $mf/p$ ,  $mfz$ , and  $(poco)$ . Pedal markings  $(PED)$  are shown below the staff with arrows.

Handwritten musical score for the third system. It consists of two staves. The top staff has a treble clef and notes with a  $5:4$  interval bracket, a  $3:2$  interval bracket, and a  $5:4$  interval bracket. Dynamic markings include  $(ppp)$  and  $(p)$ . The bottom staff has a bass clef and notes with a  $5:4$  interval bracket and a  $3:2$  interval bracket. Dynamic markings include  $p$  and  $pp$ . Pedal markings  $(PED)$  are shown below the staff with arrows. The system concludes with a final cadence marked with a double bar line and a fermata.

VIII  $\downarrow = \frac{9}{6}$  TIMELESSLY

Handwritten musical score for the first system, consisting of two staves. The notation is dense with chords and includes a marking "L (PED)" with an arrow pointing to the right. The music is written in a style that suggests a slow, sustained texture.

Handwritten musical score for the second system, consisting of two staves. It features a dynamic marking "pp" and the instruction "Loco" written above the upper staff. A chord symbol "Ab Bb E4" is visible below the lower staff. The notation continues with complex chordal structures.

Handwritten musical score for the third system, consisting of two staves. It features a dynamic marking "pp" and the instruction "Loco" written above the upper staff. The notation continues with complex chordal structures.

Handwritten musical score system 1, consisting of two staves. The top staff begins with a treble clef and a dynamic marking of *pp*. The bottom staff begins with a bass clef. The music is written in a key with one sharp (F#) and a common time signature. The system concludes with a double bar line. Below the staves, the instruction "(PED)" is written with an arrow pointing to the right.

Handwritten musical score system 2, consisting of two staves. The top staff begins with a treble clef and a dynamic marking of *pp*. The bottom staff begins with a bass clef. The music is written in a key with one sharp (F#) and a common time signature. The system concludes with a double bar line. Below the staves, the instruction "(PED)" is written with an arrow pointing to the right.

Handwritten musical score system 3, consisting of two staves. The top staff begins with a treble clef and a dynamic marking of *pp*. The bottom staff begins with a bass clef. The music is written in a key with one sharp (F#) and a common time signature. The system concludes with a double bar line and the instruction "(NO PAUSE)" written to the right. Below the staves, the instruction "(PED)" is written with an arrow pointing to the right.

# LEVY FLIGHTS — WITH TURBULENCE

VERY FAST, BUT NOT SO AS TO LOSE DETAIL

T<sup>1</sup>: ♭ = 104

pppp - 7.  $\frac{1}{2} p$   
(3p) --> (TO SILENT)

(pppp)  $\frac{1}{2} p$   
(3p) mf

T<sup>2</sup>: ♭ = 112

(mf)  $\frac{1}{2} p (1)$

Handwritten musical score system 1. It consists of two staves. The upper staff is in treble clef and the lower staff is in bass clef. The music is in a key with one sharp (F#) and a 2/4 time signature. The upper staff begins with a dynamic marking of *(mf)*. A first ending bracket is marked with a '1' above it. A second ending bracket is marked with an 'f' above it. Below the staves is a rhythmic line with a  $\frac{1}{2}p$  marking and a circled '1'.

Handwritten musical score system 2. It consists of two staves. The upper staff is in treble clef and the lower staff is in bass clef. The music is in a key with one sharp (F#) and a 2/4 time signature. The upper staff begins with a dynamic marking of *f*. A first ending bracket is marked with an '8' above it. A second ending bracket is marked with an 'f' above it. The system concludes with a section marked 'LOCO' with a dashed line and arrow above it. Below the staves is a rhythmic line with a  $\frac{1}{2}p$  marking and a circled '1'. There are also some handwritten annotations like '5-4' and '7' near the end of the system.

Handwritten musical score system 3. It consists of two staves. The upper staff is in treble clef and the lower staff is in bass clef. The music is in a key with one sharp (F#) and a 2/4 time signature. The upper staff begins with a dynamic marking of *(pp)*. A first ending bracket is marked with a '3:2' above it. A second ending bracket is marked with a '3:2' below it. Below the staves is a rhythmic line with a  $\frac{1}{2}p$  marking.

(SAME TEMPO)

Handwritten musical score for the first system. It consists of two staves. The top staff begins with a circled section of notes, followed by a section marked *ppp*. A large slur covers the entire system. The bottom staff contains rhythmic accompaniment with notes grouped in pairs. A  $\frac{1}{2} p$  dynamic marking is written below the first staff. A bracket labeled "3:2" spans a measure in the top staff, and another bracket labeled "5:4" spans a measure in the top staff. A bass clef with a flat sign is visible below the second staff.

Handwritten musical score for the second system. It consists of two staves. The top staff starts with a circled section, followed by a section marked *mf*. A tempo marking  $T^\circ 5: \downarrow = 96$  is written above the staff. A large slur covers the system. The bottom staff has rhythmic accompaniment. A  $\frac{1}{2} p$  dynamic marking is written below the first staff. A bracket labeled "5:4" is present in the top staff. A bass clef with a flat sign is written below the second staff.

Handwritten musical score for the third system. It consists of two staves. The top staff contains a complex rhythmic pattern with notes grouped in pairs and marked with accents. The bottom staff has rhythmic accompaniment. A  $\frac{1}{2} p$  dynamic marking is written below the first staff. The system is marked with various dynamics including *mf*, *f*, and *mp*.

T<sup>o</sup>1

Handwritten musical score for the first system, measures 1-8. The top staff is in treble clef and the bottom staff is in bass clef. The time signature is 1/2. Dynamic markings include *mf*, *f*, *mf*, and *ppp*. A *Loco* marking is present above the top staff in measure 8. The notation includes many beamed notes and slurs.

T<sup>o</sup>3  $\downarrow = 120$

Handwritten musical score for the second system, measures 9-16. The top staff is in treble clef and the bottom staff is in bass clef. The time signature is 1/2. Dynamic markings include *ppp* and *ff*. A *(D4)* marking is present below the bottom staff in measure 10. The notation includes many beamed notes and slurs.

T<sup>o</sup>4:  $\downarrow = 132$  MARTELLATO

Handwritten musical score for the third system, measures 17-24. The top staff is in treble clef and the bottom staff is in bass clef. The time signature is 1/2. Dynamic markings include *ff* and *ppp*. A *MARTELLATO* marking is present above the top staff in measure 20. The notation includes many beamed notes and slurs.

(simile)

Handwritten musical score for the first system. It consists of two staves. The upper staff begins with a series of eighth notes with accents, followed by a sequence of chords. The lower staff contains a similar rhythmic pattern. A circled '8' is written below the first few notes of the lower staff. The dynamic marking  $\frac{1}{2}p$  is written below the first staff. The word *(simile)* is written above the first staff. The system concludes with a right-pointing arrow.

(DELICATELY)

Handwritten musical score for the second system. It consists of two staves. The upper staff features a melodic line with some grace notes and a dynamic marking of *mf*. The lower staff continues the rhythmic accompaniment. A circled '8' is written below the first few notes of the lower staff. The dynamic marking  $\frac{1}{2}p$  is written below the first staff. The word *(DELICATELY)* is written above the second staff. The instruction *(PED) (FULL)* is written below the second staff. The system concludes with a right-pointing arrow.

(PED) (FULL)

Handwritten musical score for the third system. It consists of two staves. The upper staff has a melodic line with various intervals and a dynamic marking of *(mf)*. The lower staff has a bass line with a similar dynamic marking. A circled '8' is written below the first few notes of the lower staff. The instruction *(PED) (FULL)* is written below the first staff. The system concludes with a right-pointing arrow.

(PED) (FULL)



Handwritten musical score for the first system. It consists of two staves. The upper staff begins with a treble clef and a key signature of two sharps (F# and C#). The lower staff begins with a bass clef and the same key signature. The music is marked with a dynamic of *(mf)* and includes various accidentals (sharps, flats, naturals) and slurs. A first ending bracket labeled "1" is present. The system concludes with a dynamic marking of *p*.

(PED)  
(FULL)

MUCH SLOWER, CANTABILE

Handwritten musical score for the second system. It consists of two staves. The upper staff features a melodic line with a large slur and a dynamic marking of *sfz*. The lower staff provides accompaniment with a dynamic marking of *f*. The system includes a key signature change to one sharp (F#) and a time signature change to 5/4. A *sfz* marking is also present at the end of the system.

1/2p

Handwritten musical score for the third system. It consists of two staves. The upper staff begins with a treble clef and a key signature of one sharp (F#). The lower staff begins with a bass clef and the same key signature. The music is marked with a dynamic of *(f)* and includes various accidentals and slurs. The system concludes with a dynamic marking of *mf* and a *sfz* marking.

(PED)

POCO RIT.

I°5

Handwritten musical score for the first system. It consists of two staves with treble and bass clefs. The music is in a key with one sharp (F#) and a 2/4 time signature. The first staff begins with a piano (*p*) dynamic and a fermata. The second staff starts with a forte (*f*) dynamic, marked "SUDDENLY!", and includes "poco" markings. A pedal point is indicated by "(PED)" at the beginning. A dynamic marking of  $\frac{1}{2}p$  is written below the first staff.

Handwritten musical score for the second system. It continues the two-staff notation. The first staff starts with a forte (*f*) dynamic and includes accents (>). The second staff shows dynamic changes from *f* to *ff* and back to *f*, ending with a piano (*p*) dynamic. A dynamic marking of  $\frac{1}{2}p$  is written below the first staff.

I°2

Handwritten musical score for the third system. It continues the two-staff notation. The first staff begins with a piano (*p*) dynamic. The second staff also maintains a piano (*p*) dynamic. A dynamic marking of  $\frac{1}{2}p$  is written below the first staff.

T<sup>o</sup>3

8

1/2p

3p

8

1/2p

3p

1/2p

mf

Handwritten musical score system 1. It consists of two staves. The upper staff is in treble clef and contains a melodic line with many accidentals (sharps and flats) and slurs. The lower staff is in bass clef and contains a bass line with similar complexity. Dynamic markings include *(mf)*, *(b)*, and *ff!*. A  $\frac{1}{2}p$  (W) marking is written below the first staff.

Handwritten musical score system 2. It consists of two staves. The upper staff is in treble clef and the lower staff is in bass clef. Both staves feature dense musical notation with many accidentals and slurs. Dynamic markings include *ff*, *p*, and *ff!*. A  $\frac{1}{2}p$  marking is written below the first staff.

Handwritten musical score system 3. It consists of two staves. The upper staff is in treble clef and the lower staff is in bass clef. The notation is dense with many accidentals and slurs. Dynamic markings include *ff* and *fff*. A  $\frac{1}{2}p$  (W) marking is written below the first staff.

Handwritten musical score for the first system. It consists of a treble staff and a bass staff. The treble staff contains a melodic line with various note values and rests, including some slurs. The bass staff contains a more complex rhythmic accompaniment with many beamed notes and slurs. A dynamic marking of  $\text{pp}$  is present in the bass staff. Below the staves, there is a series of rhythmic pulses and a  $\frac{1}{2}$  note marking.

I<sup>o</sup>1

Handwritten musical score for the second system. It consists of a treble staff and a bass staff. The treble staff continues the melodic line with slurs and dynamic markings. The bass staff continues the rhythmic accompaniment. A dynamic marking of  $\text{pp}$  is present in the bass staff. Below the staves, there is a series of rhythmic pulses and a  $\frac{1}{2}$  note marking.

I<sup>o</sup>3

Handwritten musical score for the third system. It consists of a treble staff and a bass staff. The treble staff contains a melodic line with slurs and dynamic markings. The bass staff contains a complex rhythmic accompaniment with many beamed notes and slurs. Performance instructions include  $\text{pp}$ ,  $\text{Loco}$ , and  $\text{No PED}$ . Below the staves, there are various rhythmic markings such as  $\frac{3}{2}$ ,  $\frac{5}{4}$ , and  $\frac{3}{2}$ .

T<sup>o</sup>4 - WITH BRAVURA

Handwritten musical score for the first system, featuring two staves. The music is written in a complex, rhythmic style with many sixteenth and thirty-second notes. Dynamic markings include *mf*, *f*, *pp*, and *ff*. There are several circled sections and arrows pointing to specific notes. Above the staves, there are notes like *(Loco)* and *(E♭ D♭)*. Below the staves, there are notes like *(A♯ B♯)* and *(B♯)*. A bracketed note at the bottom says *(\* NB PATTERN CHANGES)*. There are also some numbers like 9=8 and 5=4 written below the staves.

Handwritten musical score for the second system, continuing the complex rhythmic patterns. It features two staves with dynamic markings like *ff* and *1/2p*. There are circled sections and arrows. Notes above the staves include *(Loco)* and *(E♭ D♭)*. Notes below include *(A♯ B♯)* and *(B♯)*. A bracketed note at the bottom says *(Loco)*.

Handwritten musical score for the third system. It features two staves. A section is marked *p! SUDDENLY*. There are dynamic markings like *1/2p* and *3p*. Notes above the staves include *(E♭ D♭)* and *(A♯ B♯)*. Notes below include *(B♯)* and *(PED)*. There are also some numbers like 6=5 and 7=5 written below the staves.

8

(p)

1/2p (3p)

G# A# C# F#

(Loco)

MUCH SLOWER - SEMPLICE

(Loco)

(p)

pp

(ppp)

1/2p (1) (3p)

F# G# A# D#

(MED)

(ppp)

pppp

L 1/2p

1/2p

(SIMILE)

(Loco)

(Loco)

Handwritten musical score for the first system. It consists of two staves: a treble staff and a bass staff. The treble staff contains a complex melodic line with many slurs and accents. The bass staff contains a rhythmic accompaniment with many slurs and accents. Dynamic markings include  $(fff)$  and  $\frac{1}{2}p$ . Rhythmic markings include  $F:G$ ,  $9:8$ , and  $\frac{1}{2}p$ . There are also some numerical markings like 8 and 3.

Handwritten musical score for the second system. It consists of two staves: a treble staff and a bass staff. The treble staff contains a complex melodic line with many slurs and accents. The bass staff contains a rhythmic accompaniment with many slurs and accents. Dynamic markings include  $(fff)$ ,  $\frac{1}{2}p$ , and  $mf$ . Rhythmic markings include  $F:G$ ,  $5:6$ ,  $5:4$ , and  $9:8$ . There are also some numerical markings like 8 and 3.

Handwritten musical score for the third system. It consists of two staves: a treble staff and a bass staff. The treble staff contains a complex melodic line with many slurs and accents. The bass staff contains a rhythmic accompaniment with many slurs and accents. Dynamic markings include  $(fff)$  and  $\frac{1}{2}p$ . Rhythmic markings include  $5:4$ ,  $3:2$ , and  $187$ . There are also some numerical markings like 8 and 7.

(CATCH AND SUSTAIN RESONANCE)



Handwritten musical score for measures 247-249. The score consists of two staves, treble and bass clef. The music is written in a complex, rhythmic style with many notes and rests. Dynamic markings include *ppp* and *pp*. A section labeled "Loco" is marked with a circled "L" and a treble clef. A "T°2" marking is at the top right.

1/2p →

Handwritten musical score for measures 307-309. The score consists of two staves, treble and bass clef. The music is written in a complex, rhythmic style with many notes and rests. Dynamic markings include *ppp* and *pp*. A section labeled "T°1" is marked at the top right.

1/2p →

Handwritten musical score for measures 307-309. The score consists of two staves, treble and bass clef. The music is written in a complex, rhythmic style with many notes and rests. Dynamic markings include *ppp* and *pp*. A section labeled "VC" is marked at the bottom left and a "(TC)" marking is at the bottom right.

1/2p →

Handwritten musical score for the first system. It consists of two staves with a treble clef on the top staff and a bass clef on the bottom staff. The music is written in a key with one sharp (F#) and a common time signature. Dynamics include *pp*, *pp* 3:2, *pp*, and *mf*. There are slurs over the first and last measures. A circled 'UC' is written below the first measure, with a dashed line extending to the right. A  $\frac{1}{2}p$  marking with an arrow is on the left.

Handwritten musical score for the second system. It consists of two staves with a treble clef on the top staff and a bass clef on the bottom staff. The music is written in a key with one sharp (F#) and a common time signature. Dynamics include *pppp!* and *pp*. There are slurs over the first and last measures. Three circled 'UC' markings are present: one at the beginning, one in the middle, and one at the end, with dashed lines extending to the right. A  $\frac{1}{2}p$  marking with an arrow is on the left.

Handwritten musical score for the third system. It consists of two staves with a treble clef on the top staff and a bass clef on the bottom staff. The music is written in a key with one sharp (F#) and a common time signature. Dynamics include *pp* and *ppp*. There are slurs over the first and last measures. A circled 'UC' is written below the first measure, with a dashed line extending to the right. A  $\frac{1}{2}p$  marking with an arrow is on the left. Rhythmic markings include 3:2, 5:4, and 3:4.

# EM FUGUE A

$\text{♩} = 46$

Handwritten musical score for 'EM FUGUE A'. The score consists of two systems of staves. The first system includes a treble clef staff with a melodic line and a bass clef staff with a bass line. The tempo is marked  $\text{♩} = 46$ . The first system is marked *pp* and includes a circled '3D' with a dashed arrow pointing right. The second system also has a treble and bass staff, marked *mf (poco)* and *ppp (QUASI-ECHO)*. It includes a circled '3P' with a dashed arrow pointing right. Various rhythmic intervals are indicated with brackets and labels such as 5:4, 3:2, 9:8, and 7:8. There are also dynamic markings like *pp*, *mf*, and *ppp*.

$\text{♩} = 56$  LTRICALLY

Handwritten musical score for 'EM FUGUE A' with a boxed 'B1' at the beginning. The tempo is marked  $\text{♩} = 56$  and the instruction 'LTRICALLY' is written below the tempo. The score consists of a single system of staves with a treble clef staff and a bass clef staff. The piece is marked *pp*. It features several measures with complex rhythmic patterns, indicated by brackets and labels such as 7:8, 9:8, 3:2, and 7:6. A circled 'L 1/2 P' with a dashed arrow pointing right is located at the bottom left. The score is heavily annotated with notes, rests, and dynamic markings.

Handwritten musical score for the first system, consisting of two staves. The music is written in a complex, non-standard rhythmic style. Above the staves, various rhythmic groupings are indicated with brackets and ratios: 3:2, 5:4, 3:2, 5:4, 9:8, 7:8, and 7:8. Below the staves, further groupings are marked with 9:8 and 5:4. The dynamic marking (mp) is present at the beginning. A  $\frac{1}{2}p$  marking is written below the first staff.

Handwritten musical score for the second system, consisting of two staves. The music continues with complex rhythmic patterns. Above the staves, rhythmic groupings are marked with brackets and ratios: 5:4, 7:8, 7:8, 9:8, 7:6, 5:6, and 7:8. Dynamic markings include mfz and pp. A  $\frac{1}{2}p$  marking is written below the first staff. At the end of the system, there are markings for mfz and pp.

$\text{♩} = 48$  PESANTE - BUT SUBTLY

Handwritten musical score for the third system, consisting of two staves. A circled 'C1' is written in a box at the beginning. The music features complex rhythmic patterns. Above the staves, rhythmic groupings are marked with brackets and ratios: 9:8, 9:8, 7:8, 3:2, and 3:2. Dynamic markings include pp and mf. Below the first staff, there is a marking for  $\frac{1}{2}$  PED and a '5' with an arrow. At the end of the system, there is a '7:8' marking with an arrow.

$\text{♩} = 50 \text{ pp}$

ppp pp

(A3)

(A4) (ppp) PED →

8

5=4

PED

**B2**

pp mfz mf

$7=8$   $3=2$   $7=8$   $9=8$   $7=8$   $7=6$

*CRESU...*

pp mfz mf

$\frac{1}{2} p$

$7=8$   $7=8$   $3=2$   $5=4$   $9=8$   $5=4$   $3=2$

Handwritten musical score for the first system, featuring two staves. The notation includes various rhythmic markings such as  $5=4$ ,  $9=8$ , and  $5=6$ . Dynamic markings include  $ff$ ,  $mf$ , and  $pp$ . A  $CRESU$  (Crescendo) marking is present. The system concludes with a double bar line and a  $3:2$  ratio.

$\frac{1}{2}p$

Handwritten musical score for the second system, featuring two staves. It includes boxed labels  $C2$ ,  $B3$ , and  $D1 = GA$ . Rhythmic markings like  $7$ ,  $5=4$ , and  $9=8$  are present. Dynamic markings include  $pp$  and  $ppp$ . A  $\frac{1}{2}PED$  (pedal) marking is shown with an arrow. The system ends with a double bar line and a  $ppp$  marking.

Handwritten musical score for the third system, featuring two staves. The notation consists of vertical lines and chords, with dynamic markings  $ppp$  and  $pp$ . A  $(PED)$  marking is present at the beginning.

Handwritten musical score for the fourth system, featuring two staves. It includes a  $(G4 Eb D#)$  marking. Dynamic markings include  $ppp$ ,  $p$ , and  $pp$ . Rhythmic markings like  $5=6$ ,  $7=8$ , and  $3=2$  are present. A  $(WITH GRACENOTE)$  marking is at the bottom. The system ends with a double bar line and a  $ppp$  marking.

Handwritten musical score for two staves. The top staff features complex rhythmic patterns with notes beamed together. Annotations include  $5$ ,  $5=4$ ,  $pppp$ ,  $8 \text{ } 7 \text{ } 4$ ,  $ppp$ ,  $2+7 \text{ } 0$ ,  $5=6$ ,  $5=4$ ,  $mf$ ,  $7 \text{ } \# \text{ } 4$ , and  $3$ . The bottom staff has notes with stems pointing down, including a circled  $(Eb)$ . Pedal markings ( $ped$ ) are present under both staves. A circled  $(6)$  is written below the bottom staff.

Handwritten musical score for two staves. The top staff contains notes with stems pointing up. The bottom staff has notes with stems pointing down. A circled  $(A)$  is written below the bottom staff. A  $ppp$  dynamic marking is also present.

Handwritten musical score for two staves. A tempo marking  $\text{♩} = 54$  is written above the first staff. The top staff has notes with stems pointing up, including a circled  $(B)$ . The bottom staff has notes with stems pointing down, including a circled  $(A)$ . Annotations include  $3=2$ ,  $5=4$ ,  $9=8$ ,  $5=6$ ,  $5=4$ ,  $7=6$ , and  $3=2$ . Pedal markings ( $ped$ ) are present under the bottom staff.

(p) (16) 56  
EI VI-6

9=8 5=4 3=2

PED

**BOLDLY**

BA

7=8 5=4 7=8 3 3 5=4 7=8

9=8 5=4 3=2 5 5=4 5 9=8

$\frac{1}{2}p$

(ff)

5=4 7=8 9=8 5=4 3=2

7=8 9=8 5=4 3=2

$\frac{1}{2}p$



VI-7

Handwritten musical score for VI-7. The score consists of two staves, Treble and Bass clef. It features complex chordal textures with many accidentals (sharps and flats). Rhythmic markings include  $9:8$ ,  $3:2$ ,  $7:8$ , and  $5:4$ . Dynamics include  $mf$ ,  $pp$ , and  $ppp$ . Pedal markings include  $L PED$  and  $(II)$ . There are also some handwritten notes like  $2+3$ ,  $2+4$ , and  $2+6$ .

Handwritten musical score for a section with four measures. The score consists of two staves, Treble and Bass clef. It features complex chordal textures with many accidentals. Rhythmic markings include  $11/8$ ,  $3:2$ ,  $5:4$ , and  $3:2$ . Dynamics include  $mf$ ,  $pp$ , and  $ppp$ . Pedal markings include  $L PED$  and  $(1)$ . There are also some handwritten notes like  $(1)$ ,  $(2)$ , and  $(3)$ .

Handwritten musical score for a section with four measures. The score consists of two staves, Treble and Bass clef. It features complex chordal textures with many accidentals. Rhythmic markings include  $3:2$ ,  $5:4$ , and  $5:6$ . Dynamics include  $mf$  and  $ppp$ . Pedal markings include  $L PED$  and  $(F)$ . There are also some handwritten notes like  $(3)$  and  $(F)$ .

Handwritten musical score for the first system. It consists of two staves with complex rhythmic patterns. Above the staves, there are several time signature changes: 9:8, 3, 5:4, 3:2, 9:8, 5:4, 3:2, and 7:6. Below the staves, there are more time signature changes: 5:4, 3:2, 3, 3:2, and 7:8. A dynamic marking of  $mf$  is present. At the bottom left, there is a handwritten instruction:  $(1) \frac{1}{2}$  PED  $\rightarrow$ .

Handwritten musical score for the second system. It features two staves with complex rhythmic patterns. A tempo marking at the top left indicates a quarter note equals 58 ( $\text{♩} = 58$ ). Dynamic markings include  $mf$  and  $ppp$ . A circled 'E1' is written on the right side. Above the staves, there are time signature changes: 9:8, 5:4, 3:2, 5:4, 5:4, 5:4, 9:8, 3:2, and 7:8. A circled 'AS' is written on the left side. At the top right, there is a handwritten instruction: (AS FAST AS POSSIBLE)  $ppp$ .

Handwritten musical score for the third system. It features two staves with dense rhythmic notation. Dynamic markings include  $ppp$  and  $(Loco)$ . A circled 'AS' is written on the left side. At the bottom left, there is a handwritten instruction: (PED). At the bottom right, there is a handwritten instruction:  $mf$ .

(Poco)

Handwritten musical score for the first system, consisting of three staves. The top staff contains several measures of music with dynamic markings *p*, *f*, and *mp*, and a *5:4* ratio. The middle and bottom staves contain dense rhythmic patterns. A *p* marking is present at the beginning of the middle staff.

(PED) (A) →

Handwritten musical score for the second system, consisting of three staves. The top staff has dynamic markings *mf*, *f*, *sfz*, and *mp*, along with a *3:2* ratio. The middle and bottom staves continue the rhythmic patterns. A large fermata is placed over the end of the system, with a *mp* marking above it.

(PED)

FRAGMENTARY

35

VI-10

Handwritten musical score for the first system. It consists of two staves. The upper staff is in treble clef and the lower staff is in bass clef. The music is characterized by complex rhythmic patterns with various note values and rests. Dynamic markings include *ff*, *f*, and *fz*. Rhythmic annotations such as  $5:4$ ,  $3:2$ ,  $7:8$ , and  $9:8$  are present. A bracketed section in the lower staff is labeled "(MINIMAL PEDAL)".

Handwritten musical score for the second system. It consists of two staves. The upper staff is in treble clef and the lower staff is in bass clef. The music continues with complex rhythmic patterns and dynamic markings such as *ff*, *f*, and *fz*. Rhythmic annotations include  $9:8$ ,  $7:6$ ,  $5:4$ ,  $3:2$ , and  $7:8$ . A bracketed section in the lower staff is labeled "(LEGATO!)".

Handwritten musical score for the third system. It consists of two staves. The upper staff is in treble clef and the lower staff is in bass clef. The music concludes with dynamic markings such as *ppp!*, *ppp*, and *loco*. Rhythmic annotations include  $5:4$ ,  $3:2$ ,  $7:8$ , and  $9:8$ . A bracketed section in the lower staff is labeled "(LEGATO!)". The system ends with a "PED" instruction and an arrow pointing to the right.

VI-11

Musical notation for VI-11, featuring a treble clef and a bass clef. The music consists of complex chords and melodic lines. Dynamics include *pp* and *mp*. A vertical bar line is present. The word "Loco" is written in the bass staff.

(PED)

A large, complex musical score with multiple systems. It includes various dynamic markings such as *ff*, *pp*, *ppp*, and *mp*. Time signatures include  $\frac{3}{5}$ ,  $\frac{3}{2}$ ,  $\frac{5}{4}$ , and  $\frac{5}{6}$ . The score features intricate chordal textures and melodic lines. Pedal markings (PED) are used throughout. A circled "3P" is visible in the lower system. The notation is dense and includes many accidentals and articulation marks.

D3

$\frac{3}{5}$

3P

$\frac{3}{2}$

3P

(p)

ppp - pp

ppp

pp

Handwritten musical score for VI-12, featuring complex rhythmic patterns and dynamic markings. The score is divided into several sections with various time signatures and dynamic levels.

**Section 1 (Top):** Includes time signatures  $9:8$  and  $5:6$ . Dynamic markings include  $mf$ ,  $ppp$ , and  $ff$ . A  $v/1$  marking is present. A  $(PED)$  instruction is at the bottom left.

**Section 2 (Middle):** Includes time signatures  $5:4$ ,  $7:8$ ,  $5:4$ , and  $3:2$ . Dynamic markings include  $p$ ,  $ff$ , and  $ppp$ . A  $(PED)$  instruction is at the bottom left.

**Section 3 (Bottom):** Includes time signatures  $7:8$ ,  $9:8$ ,  $7:8$ ,  $5:4$ , and  $3:2$ . Dynamic markings include  $ppp$  and  $ff$ . A  $(PED)$  instruction is at the bottom left.

Handwritten musical score for section A6, titled "GLASSILY".

**Section A6:** Includes time signatures  $7:6$ ,  $5:4$ , and  $3:2$ . Dynamic markings include  $mfz/pp$ . A circled "A6" is at the top left. A circled "62" is above the first staff. A circled "3p" is at the bottom left, with "(POLA PED.)" below it.

\*NOT TOO FAST:



VL-1A

Handwritten musical score for the first system. It consists of two staves: a treble clef staff on top and a bass clef staff on the bottom. The music is written in a complex, rhythmic style with many slurs and accents. Dynamic markings include *p* (piano) and *mfz* (mezzo-forte). Rhythmic values are indicated by numbers above or below notes, such as 9:8, 5:4, 3:2, 7, 5, and 9:8. There are also some handwritten annotations like 'mfz' and 'fz' with arrows pointing to specific notes.

Handwritten musical score for the second system. It continues the piece with two staves (treble and bass clef). The notation is dense with slurs and accents. Dynamic markings include *p*, *mfz*, and *sfz* (sforzando). Rhythmic values are indicated by numbers, such as 5:4, 3:2, 7:8, 5:4, 3:2, 9:8, 3, 5:4, 9:8, 3, and 5:4. There are also some handwritten annotations like 'mfz' and 'sfz' with arrows pointing to specific notes.

Handwritten musical score for the third system. It concludes the piece with two staves (treble and bass clef). The notation is dense with slurs and accents. Dynamic markings include *p*. Rhythmic values are indicated by numbers, such as 9:8, 3:2, 5, 9:8, 3, 3, 3, 6:5, and 9:8. There are also some handwritten annotations like 'mfz' and 'sfz' with arrows pointing to specific notes.



Handwritten musical notation for a piano introduction. It features a treble clef with a key signature of two flats (B-flat and E-flat) and a common time signature. The right hand has a melodic line with a 5:4 interval marked. The left hand has a bass line with a 7:4 interval marked. A 'p' dynamic marking is present. Below the staves, there are guitar chord diagrams for the left hand and a '(PED)' marking.

PESANTE — STATELY & GRAVE

VI-15

Handwritten musical notation for the first system of the 'PESANTE' section. It consists of two staves (treble and bass clefs) with a key signature of two flats. The notation is heavily annotated with interval markings such as 7:6, 5:4, 3:2, 9:8, and 7:8. A 'CA' box is present at the beginning. The piece concludes with a double bar line and a 3/2 time signature.

Handwritten musical notation for the second system of the 'PESANTE' section. It continues from the first system with two staves (treble and bass clefs) and a key signature of two flats. It features similar interval markings (5:4, 9:8, 7:8, 5:4, 3:2, 5:6) and concludes with a double bar line.

Handwritten musical score for the first system. It consists of two staves: a treble clef staff on top and a bass clef staff on the bottom. The music is written in a complex, rhythmic style with many notes and accidentals. Above the treble staff, there is a box labeled 'D4' and a '3:2' ratio. Below the bass staff, there is a '3:2' ratio and a '(PED)' marking. To the right, there are '7:8' and '7:8' ratios and a '3' marking. The music ends with a double bar line and a fermata.

Handwritten musical score for the second system. It consists of two staves: a treble clef staff on top and a bass clef staff on the bottom. The music continues with complex rhythmic patterns and many notes and accidentals. Above the treble staff, there is a '3:2 V/3' ratio and a 'p' marking. Below the bass staff, there is a 'p' marking and a '(p) (c) (ec)' marking. To the right, there is a 'p' marking and a '7' marking. The music ends with a double bar line and a fermata.

(PED)

**B6** = 56 FLORIDLY - MOLTO LEGATO

Handwritten musical score for the third system, titled 'FLORIDLY - MOLTO LEGATO'. It consists of two staves: a treble clef staff on top and a bass clef staff on the bottom. The music is written in a complex, rhythmic style with many notes and accidentals. Above the treble staff, there is a 'mf' marking and a '3:2' ratio. Below the bass staff, there is a '3:2' ratio and a '1/2 p' marking. To the right, there is a '7:8' ratio, a '9:8' ratio, a '7:8' ratio, a '5:4' ratio, a '2' marking, a '3' marking, a '9:8' ratio, and a '3' marking. The music ends with a double bar line and a fermata.

Handwritten musical score for the first system, featuring two staves. The notation includes complex rhythmic patterns with various time signatures such as 5/4, 3/2, 7/8, and 9/8. The score is marked with dynamic levels including  $\frac{1}{2}p$  and  $ff$ . A circled plus sign (+) is present in the first measure of the upper staff. The piece concludes with a fermata over the final notes.

F2  $\downarrow = 46$

Handwritten musical score for the second system, consisting of two staves. The notation continues with complex rhythmic structures, including time signatures like 5/4, 7/8, 3/4, 3/2, and 9/8. Dynamic markings include  $\frac{1}{2}p$ ,  $ff$ , and  $fff$ . The score features several slurs and accents, and ends with a fermata.

Handwritten musical score for the third system, also in two staves. The notation includes complex rhythmic patterns with time signatures such as 3/2, 5/4, 9/8, and 7/6. Dynamic markings include  $\frac{1}{2}p$ ,  $ff$ , and  $fff$ . The system concludes with a fermata over the final notes.

MOMENTARILY FROZEN

VI-18

Handwritten musical score for the first system. It consists of two staves with complex rhythmic patterns. Above the staves, there are numerous time signature changes and bar groupings, including 9:8, 5:4, 3:2, and 7:8. Dynamic markings include  $\frac{1}{2}p$ ,  $f$ , and  $sfz$ . A vertical line on the right side of the system is labeled "MOMENTARILY FROZEN" and "5''".

Handwritten musical score for the second system, starting with the word "GLASSILY" written above the staff. It features two staves with complex rhythmic patterns and time signature changes such as 5:4, 7:8, 3:2, and 9:8. Dynamic markings include  $ff$ .

(E3) AS FAST AS POSSIBLE

Handwritten musical score for the third system. It features two staves with complex rhythmic patterns and time signature changes such as 7:8, 5:4, and 3:2. Dynamic markings include  $f$ ,  $sfz$ ,  $mf$ , and  $fff$ . A circled "E3" is written above the staff with the instruction "AS FAST AS POSSIBLE". At the end of the system, there is a circled "Loco" and a large arrow pointing right labeled "(fff)".

*sfz sfz sfz sfz*

*7=6*

*= 60*

*3:2*

*(ACCEL)*

*DEFT, AGILE, WITH PRECISION*

*mfz*

*sfz*

*(LoCo)*

*(LoCo)*

*f*

*9:8*

*7:8*

*3:2*

*9:8*

*PED*

Detailed description of the first system: This system contains two staves. The upper staff is in treble clef and begins with a series of sixteenth-note chords marked with *sfz*. It features a *7=6* interval and a tempo marking of *= 60*. A large slur covers the right half of the system, with the instruction *(ACCEL) DEFT, AGILE, WITH PRECISION* written above it. The lower staff is in bass clef and contains a *(LoCo)* section with a *7=6* interval. It includes dynamic markings like *f* and *sfz*, and rhythmic notations such as *9:8*, *7:8*, and *3:2*. A *PED* (pedal) line is indicated at the bottom left.

*(ACCEL)*

*7:8*

*3:2*

*5:4*

*5:4*

*3:2*

*3:2*

*9:8*

*9:8*

*(PED)*

*(MINIMAL PEDAL)*

Detailed description of the second system: This system continues the piece with two staves. The upper staff features a melodic line with various intervals marked as *7:8*, *3:2*, *5:4*, and *9:8*. The lower staff provides harmonic support with similar intervals. A *(ACCEL)* marking is at the beginning. A *(PED)* line is shown at the bottom left, with the instruction *(MINIMAL PEDAL)* written below it.

Handwritten musical score for the first system, featuring a treble and bass clef. The tempo is marked  $\text{♩} = 63$ . The music includes various rhythmic patterns with annotations such as  $5:4$ ,  $9:8$ ,  $7:8$ , and  $3:2$ . The notation includes notes, rests, and dynamic markings like  $\text{ff}$ .

Handwritten musical score for the second system, starting with the instruction **(ACCEL.)**. The tempo is marked  $\text{♩} = 66$ . The notation continues with complex rhythmic structures and includes dynamic markings such as  $\text{ff}$  and  $\text{f}$ .

Handwritten musical score for the third system, also starting with **(ACCEL.)**. The notation includes dynamic markings like  $\text{ff}$  and  $\text{f}$ , and features complex rhythmic patterns with annotations such as  $5:4$ ,  $9:8$ , and  $3:2$ .

(ACCEL.)

♩ = 69

5:4 7:8 5:4 3:2 5:4 3:2

5:4 3:2

fff (mf) fff

7:8 7:8

(RALL.)

♩ = 69

7:8 7:8 9:8 5:6 3:2 7:8 3:2 5:4

fff

9:8 3:2 7:8 5:4 3:8 5:4

(RALL.)

(D#) (F#) (G#)

$\downarrow = 66$

This system contains a guitar chord progression: (D#), (F#), and (G#). The music is written in treble and bass clefs. It features a variety of rhythmic patterns, including eighth and sixteenth notes, and rests. Above the staff, there are several bracketed intervals labeled with ratios: 5:4, 3:2, 9:8, 7:8, and 5:4. A tempo marking  $\downarrow = 66$  is present at the top right. A dashed line with a circled '8' indicates a specific measure or group of notes.

(RALL.)

9:8 9:8 5:4 3:2 5:4 3:2 5:4 3:2 8

This system continues the musical piece with similar rhythmic complexity. It includes bracketed intervals labeled 9:8, 5:4, 3:2, and 7:8. A circled '8' is placed above the staff, and another circled '8' is placed below the staff. The notation includes various note values and rests, with some notes marked with a '7'.

(RALL.)

$\downarrow = 63$

The final system begins with a tempo change to  $\downarrow = 63$ . The music continues with complex rhythmic patterns and intervals, including 7:8, 5:4, 3:2, and 9:8. A circled '8' is visible above the staff. The piece concludes with a final chord and a double bar line.



(RALL.)

$\text{♩} = 60$

VI-23

Handwritten musical score for the first system, consisting of two staves. The music is written in treble clef with a key signature of one sharp (F#). The tempo is marked as  $\text{♩} = 60$ . The first staff begins with a dynamic marking of *mf*. The second staff has dynamic markings of *mf* and *pp*. The score is heavily annotated with rhythmic ratios such as 7:8, 3:2, and 5:4, indicating complex polyrhythmic structures. There are also some slurs and accents present.

$\text{♩} = 66$  GLASSY, AS BEFORE

Handwritten musical score for the second system, consisting of two staves. The tempo is marked as  $\text{♩} = 66$ . The first staff starts with a circled **G1** and a dynamic marking of *ff*. The second staff has dynamic markings of *pp* and *ff*. The score is annotated with rhythmic ratios including 3:2, 5:4, 7:8, 6:5, 2:8, 5:6, and 5:4. A circled **(loco)** is written above the second staff. The notation includes complex rhythmic patterns and various accidentals.

$\text{♩} = 46$  III

Handwritten musical score for the third system, consisting of two staves. The tempo is marked as  $\text{♩} = 46$ . The first staff has a dynamic marking of *ff*. The second staff has a dynamic marking of *ff*. The score is annotated with rhythmic ratios such as 5:4, 3:2, and 5:4. The notation includes complex rhythmic patterns and various accidentals.

112

INSERT (BEGINNING OF LINE 2)

2 7

4

6 A

$\downarrow = 48$

ET

Handwritten musical notation for the first system, including a treble clef, a key signature of one flat, and various notes and rests. Above the staff, there are annotations:  $19 \cdot 84$  and  $5=4$ . A large bracket spans across the top of the system.

Handwritten musical notation for the second system, featuring two staves. The left staff has a treble clef and a key signature of one flat. The right staff has a bass clef and a key signature of one flat. Annotations include  $3:2$ ,  $9=8$ , and  $5=4$ . A vertical bar line is present in the middle of the system.

Handwritten musical notation for the third system, featuring two staves. The left staff has a treble clef and a key signature of one flat. The right staff has a bass clef and a key signature of one flat. Annotations include  $7=8$ ,  $5=4$ ,  $7$  pppp,  $12$ ,  $14 \cdot 28$ ,  $18$ , and  $5=4$ . A vertical bar line is present in the middle of the system.

Handwritten musical notation for the fourth system, featuring two staves. The left staff has a treble clef and a key signature of one flat. The right staff has a bass clef and a key signature of one flat. Annotations include  $5=4$ ,  $3:2$ ,  $5=4$ ,  $3:2$ ,  $11 \cdot 11$ ,  $9=8$ ,  $25$ , and  $(12) (16)$ . A vertical bar line is present in the middle of the system.

Handwritten musical score for the first system, featuring piano and grand staves. The piano staff includes dynamic markings such as  $(pp)$ ,  $(ppp)$ , and  $(p)$ . The grand staff includes dynamic markings such as  $f=0$ ,  $f$ , and  $ff$ . Rhythmic markings include  $5:4$ ,  $3:2$ , and  $5$ . A vertical bar line is present in the middle of the system. A  $PED$  marking with an arrow is located at the bottom left.

Handwritten musical score for the second system, including piano and grand staves. The piano staff includes dynamic markings such as  $(p)$  and  $ff$ . The grand staff includes dynamic markings such as  $ff$ . A tempo marking  $\text{♩} = 66$  GLASSY... is present. A circled  $G$  with the text "ETC." below it is also present. Rhythmic markings include  $9:8$ ,  $7$ , and  $3:2$ . A vertical bar line is present in the middle of the system. A  $PED$  marking with an arrow is located at the bottom left.

A set of empty musical staves at the bottom of the page, consisting of two grand staves.

$\text{♩} = 46$  DISTANTLY, MYSTERIOUS

**F3**

Handwritten musical score for F3. The score consists of two staves. The upper staff is in treble clef and contains a series of chords with various accidentals (sharps, flats, naturals) and rhythmic markings above them, including 7:6, 9:8, 7:8, 9:8, -3-, 5, and 5:4. The lower staff is in bass clef and contains a series of chords with accidentals and rhythmic markings below them, including 9:8, 3-2, 7:8, 9:8, and 9:8. There are also markings for *p*, *mfz*, *f*, and *mf*. A large bracket labeled (PED) spans the bottom of the lower staff.

**C6**

Handwritten musical score for C6. The score consists of two staves. The upper staff is in treble clef and contains a series of chords with accidentals and rhythmic markings above them, including 7:8 and 9:8. The lower staff is in bass clef and contains a series of chords with accidentals and rhythmic markings below them, including 3:2. There are markings for *mf* and *VI*. A large bracket labeled (PED) spans the bottom of the lower staff.

AS FAST AS POSSIBLE

**E4**

Handwritten musical score for E4. The score consists of two staves. The upper staff is in treble clef and contains a dense, fast-paced texture of notes with many accidentals and rhythmic markings above them. The lower staff is in bass clef and contains a dense, fast-paced texture of notes with many accidentals and rhythmic markings below them. There are markings for *fff* and a large bracket labeled (PED) at the bottom.

Handwritten musical score for the first system, consisting of two staves. The music is written in a complex, rhythmic style with many notes and accidentals. Above the staves, there are dynamic markings: **fff sfz** and **pp (p)**. A large slur covers the right half of the system. Below the staves, there are markings: **(PED)** on the left and **pp (p)** on the right. A circled **Lo Co** is written near the end of the second staff.

**B7**  $\downarrow = 56$  (EVAPORATING)

Handwritten musical score for the second system, consisting of two staves. The music features various rhythmic ratios indicated by brackets above and below the staves:  $9:8$ ,  $5:4$ ,  $7:8$ , and  $3$ . Dynamic markings include **p**, **pp**, and **pppp**. A large slur covers the entire system.

$\downarrow = 62$

Handwritten musical score for the third system, consisting of two staves. The music includes a circled **62** at the beginning. Rhythmic ratios are marked with brackets:  $5:4$ ,  $3:2$ , and  $5:4$ . A **ppp** dynamic marking is present at the start. A **PED** marking with an arrow is at the bottom left.

D5  
B♭

5=4

5=4

D5 PROPER VIX

2

7=8

7=8

3

7=8

VI/4

7.

ff

p

9=8

9=8

5=4

7=8

9=8

9=8

5=4

7.

ppp

(ppp)

(ppp)

(ppp)

VII/2

7=8

3=2

5=4

9=8

3=2

5=4

Loco

ppp

(ppp)

(ppp)

(PED)

F4

Handwritten musical score for Violin I (VI) and Cello/Double Bass (ZF). The Violin I part is on a treble clef staff, and the Cello/Double Bass part is on a bass clef staff. The music features complex rhythmic patterns with various time signatures (9:8, 7:8, 5:4, 3:2) and dynamic markings (mp, p, sfz, p). The score includes a box labeled 'F4' at the beginning and a 'p' dynamic marking at the end.

Handwritten musical score for Violin II and Cello/Double Bass. The Violin II part is on a treble clef staff, and the Cello/Double Bass part is on a bass clef staff. The music features complex rhythmic patterns with various time signatures (9:8, 7:6, 5:4, 3:2) and dynamic markings (ff, cresc., mf). The score includes a 'p' dynamic marking at the end.

(PED)

Handwritten musical score for guitar. The score is on a treble clef staff and includes a guitar chord diagram at the beginning. The music features complex rhythmic patterns with various time signatures (7:8, 7:6) and dynamic markings (mf, p). The score includes a 'p' dynamic marking at the end.

The image displays three systems of handwritten musical notation, likely for a string quartet. The notation is dense and includes various musical symbols and annotations:

- System 1:** Features a treble clef staff with a key signature of one sharp (F#). It contains complex rhythmic patterns with notes beamed together. Above the staff, there are several circled numbers: (3), (9), (7), (4), (5), 7:6, (3), (3), (7), and 7. A dynamic marking of *ppp* is present. Below the staff, there are markings for *ppp* and *3:2* intervals.
- System 2:** Includes a bass clef staff with a key signature of one sharp. It features a large slur over a series of notes. Above the staff, there are markings for *ppp*, *3:2*, and *5:4*. A circled number (7) is visible. Below the staff, there are markings for *ppp*, *3:2*, and *5:4*. A circled number (7) is also present.
- System 3:** Shows a treble clef staff with a key signature of one sharp. It features a large slur over a series of notes. Above the staff, there are markings for *ppp*, *3:2*, and *5:4*. A circled number (7) is visible. Below the staff, there are markings for *ppp*, *3:2*, and *5:4*. A circled number (7) is also present.

Additional annotations include *(PED)* markings, *(p)* dynamics, *e sim.*, and various interval markings such as *5:6*, *7:8*, *5:4*, *7:8*, *9:8*, and *5:4*. The notation is highly detailed, with many notes beamed together and various accidentals.



58 (J4) INTENSELY

5:4 9:8 5:4 3:2

3:2 5:6 9:8 5:4

3:2 5:4 5:4 5:4 3:2

PED →

7:6 9:8 5:4 7:8 5:4 7:8 3

3:2 3:2 9:8 5:4 3 3:2 5:4

(PED) →

VI-29

9:8 5:4

5:4 3:2

(PED) →

(E5)

RAIL.

(EC)

(GA)

VI-30

Handwritten musical score for the first system. It consists of two staves: a piano staff (top) and a bass staff (bottom). The piano staff has a treble clef and a key signature of one flat. The bass staff has a bass clef and a key signature of one flat. The music is highly rhythmic, with many sixteenth and thirty-second notes. There are several slurs and accents. Dynamic markings include *f* (forte) and *pp* (pianissimo). There are also markings for *(PACO)* and *(Loco)*. A tempo marking of  $\text{♩} = 86$  is present. There are also some numerical markings like  $5:4$  and  $3:2$ .

Handwritten musical score for the second system. It consists of two staves: a piano staff (top) and a bass staff (bottom). The piano staff has a treble clef and a key signature of one flat. The bass staff has a bass clef and a key signature of one flat. The music continues with complex rhythmic patterns. Dynamic markings include *pp*, *ppp*, and *pppp*. There are also markings for *(D7)*, *(9)*, and *(7)*. A tempo marking of  $\text{♩} = 86$  is present. There are also some numerical markings like  $5:4$ ,  $3:2$ , and  $9:8$ .

Handwritten musical score for the third system. It consists of two staves: a piano staff (top) and a bass staff (bottom). The piano staff has a treble clef and a key signature of one flat. The bass staff has a bass clef and a key signature of one flat. The music starts with a tempo marking of *(AS FAST AS POSSIBLE)*. There are dynamic markings of *f* and *p*. There are also markings for *(F5)*, *(Sim)*, and *(Loco)*. A tempo marking of  $\text{♩} = 86$  is present. There are also some numerical markings like  $5:4$  and  $3:2$ . The system ends with a fermata.

pp

ppp

(-2-)

(Loco)

(-2-)

(PED)

pppp!

p

(PED)

pppp

pp

ppp

ppp

$\downarrow = 86$

(p)

5:4

(Loco)

5:4

(PED)

(G5)

QUIETLY

Handwritten musical score for the first system, featuring a treble clef and a bass clef. The tempo is marked "QUIETLY". The score includes a dynamic marking "p" and a metronome marking of 50. The music is characterized by complex rhythmic patterns and intervals, with time signatures such as 5:4, 7:8, and 9:8. A pedal point is indicated by "(PED)" in the bass clef. The notation includes various accidentals and slurs.

Handwritten musical score for the second system, continuing the piece. It features a treble clef and a bass clef. The score includes a dynamic marking "(p)" and a pedal point indicated by "(PED)". The music continues with complex rhythmic patterns and intervals, with time signatures such as 9:8, 3:2, 5:4, and 7:8. The notation includes various accidentals and slurs.

Handwritten musical score for the third system, continuing the piece. It features a treble clef and a bass clef. The score includes a dynamic marking "(p)" and a pedal point indicated by "(PED)". The music continues with complex rhythmic patterns and intervals, with time signatures such as 5:4, 3:2, 7:6, 9:8, and 5:4. The notation includes various accidentals and slurs.

MONOLITHIC:

BALDLY

F6

Handwritten musical score for the first system. It consists of two staves. The upper staff has a treble clef and contains several chords with rhythmic markings above them, including  $7:8$  and  $3:2$ . The lower staff has a bass clef and contains more complex rhythmic patterns with markings such as  $9:8$ ,  $5:4$ , and  $3:2$ . Dynamic markings include  $ff$  and  $(B4)$ . A pedal point is indicated by  $(PED)$  with an arrow pointing right.

Handwritten musical score for the second system. It consists of two staves. The upper staff has a treble clef and contains chords with rhythmic markings like  $7:8$ ,  $5:4$ ,  $9:8$ , and  $11:8$ . The lower staff has a bass clef and contains rhythmic patterns with markings like  $5:4$ . Dynamic markings include  $fff$  and  $mf$ . A pedal point is indicated by  $(PED)$  with an arrow pointing right.

Handwritten musical score for the third system. It consists of two staves. The upper staff has a treble clef and contains chords with rhythmic markings like  $5:4$  and  $9:8$ . The lower staff has a bass clef and contains rhythmic patterns with markings like  $5:4$  and  $9:8$ . Dynamic markings include  $pppp$ ,  $pp$ , and  $loco$ . A pedal point is indicated by  $(PED)$  with an arrow pointing right.

Handwritten musical score for the first system. It consists of two staves: a treble staff and a bass staff. The treble staff begins with a treble clef, a key signature of one sharp (F#), and a dynamic marking of *pp*. The bass staff begins with a bass clef and a dynamic marking of *pp*. The music is marked with various rhythmic groupings:  $5:4$ ,  $3:2$ ,  $5:4$ ,  $7:8$ ,  $5:4$ ,  $7:6$ ,  $3:2$ , and  $3:2$ . A circled number 5 is written above the treble staff. The bass staff includes a section marked *(A1)* with a fermata.

Handwritten musical score for the second system. It consists of two staves: a treble staff and a bass staff. The treble staff begins with a treble clef and a dynamic marking of *pp*. The bass staff begins with a bass clef and a dynamic marking of *pp*. The music is marked with rhythmic groupings:  $5:4$ ,  $5:4$ ,  $5:4$ , and  $9:8$ . A circled number 4 is written below the bass staff.

Handwritten musical score for the third system. It consists of two staves: a treble staff and a bass staff. The treble staff begins with a boxed **F7** marking, a treble clef, and a dynamic marking of *ppp*. The bass staff begins with a bass clef and a dynamic marking of *p*. The music is marked with various rhythmic groupings:  $5:6$ ,  $9:8$ ,  $7:8$ ,  $5:4$ ,  $5:4$ ,  $3:2$ ,  $7:8$ ,  $7:6$ ,  $5:4$ , and  $3:2$ . A circled number 8 is written below the bass staff. A *(PED)* instruction with an arrow is written below the bass staff.

Handwritten musical score for the first system. It consists of two staves: a treble clef staff and a bass clef staff. The treble staff begins with a treble clef and a key signature of one sharp (F#). The bass staff begins with a bass clef and a key signature of one sharp (F#). The music is marked with *ppp* in both staves. Above the treble staff, there are two bracketed sections labeled  $5=4$  and  $7=8$ . Below the bass staff, there are three bracketed sections labeled  $9=8$ ,  $9=8$ , and  $3=2$ . A large bracket labeled *(PED)* spans the entire duration of the system. The system ends with a double bar line.

Handwritten musical score for the second system. It consists of two staves: a treble clef staff and a bass clef staff. The treble staff begins with a treble clef and a key signature of one sharp (F#). The bass staff begins with a bass clef and a key signature of one sharp (F#). The music is marked with *pp* and *ppp*. Above the treble staff, there are three bracketed sections labeled  $5=4$ ,  $7=8$ , and  $5=4$ . Below the bass staff, there are four bracketed sections labeled  $5=4$ ,  $3=2$ ,  $3=2$ , and  $9=8$ . There are also some handwritten annotations in the bass staff, including *(B)* and *(A)*. The system ends with a double bar line.

Handwritten musical score for the third system. It consists of two staves: a treble clef staff and a bass clef staff. The treble staff begins with a treble clef and a key signature of one sharp (F#). The bass staff begins with a bass clef and a key signature of one sharp (F#). The music is marked with *(pp)* and *(ppp)*. Above the treble staff, there are five bracketed sections labeled  $5=4$ ,  $5=4$ ,  $3=2$ ,  $3=2$ , and  $5=4$ . Below the bass staff, there are four bracketed sections labeled  $5=4$ ,  $9=8$ ,  $3=8$ , and  $5=4$ . The system ends with a double bar line.

Handwritten musical score for the first system. It consists of a piano staff (top) and a bass staff (bottom). The piano staff contains a melodic line with various rhythmic values and dynamic markings. The bass staff contains a complex accompaniment with many beamed notes. Dynamic markings include *ppp* at the beginning and *pp* later on. Rhythmic markings include  $3=2$ ,  $5=4$ , and  $7=8$ . A circled  $3P$  with an arrow points to a specific measure in the piano staff.

**EM FUGUE B**  
 SINGLE LONG PHASE: BREATHLESSLY INTENSE

Handwritten musical score for the second system. It features a piano staff and a bass staff. The piano staff has a melodic line with dynamics like *mf (poco)* and *ppp*. The bass staff has a complex accompaniment. Performance instructions include *Loco* and *ppp*. Rhythmic markings include  $3=2$ ,  $5=4$ , and  $9=8$ . A circled  $3P$  with an arrow is at the start of the system.

Handwritten musical score for the third system. It features a piano staff and a bass staff. The piano staff has a melodic line with dynamics like *mf (poco)*, *mf*, and *ppp*. The bass staff has a complex accompaniment. Performance instructions include *Loco* and *ppp*. Rhythmic markings include  $3=2$ ,  $5=4$ , and  $9=8$ . A circled  $3P$  with an arrow is at the start of the system. The text "(BELL-LIKE)" is written below the piano staff with an arrow pointing to a specific note.



(v1)

B4

Handwritten musical score for system 1, measures 1-10. It features a treble and bass clef with complex rhythmic patterns and accidentals. Dynamic markings include (ppp), mf, and p. Time signatures 5:4 and 9:8 are indicated. A circled '3p' with an arrow points to the start of the system.

E2

Handwritten musical score for system 2, measures 11-20. It continues the complex rhythmic and melodic lines. Dynamic markings include /mf, f, and pp. Time signatures 5:4 and 9:8 are present. A circled '3p' with an arrow points to the start of the system.

D3

Handwritten musical score for system 3, measures 21-30. It features a series of numbered measures (2-6) with complex rhythmic patterns. Dynamic markings include ff, mf, and pp. Time signatures 5:4 and 3:2 are indicated. A circled '3p' with an arrow points to the start of the system.

(BELL-LIKE)

(p?)

Handwritten musical score for the first system. It consists of two staves: a treble staff and a bass staff. The treble staff begins with a treble clef and a key signature of one sharp (F#). The bass staff begins with a bass clef and a key signature of one sharp (F#). The score includes various musical notations such as notes, rests, and dynamic markings. Key annotations include 'AG' above the treble staff, '(pp)' in both staves, 'mf' in the treble staff, and 'SEMPLICE' in the treble staff. Rhythmic markings like '3:2' and '5:4' are present. A dashed line is drawn below the bass staff.

Handwritten musical score for the second system. It consists of two staves: a treble staff and a bass staff. The treble staff begins with a treble clef and a key signature of one sharp (F#). The bass staff begins with a bass clef and a key signature of one sharp (F#). The score includes various musical notations such as notes, rests, and dynamic markings. Key annotations include '(mf)' in the treble staff and '(pp)' in the bass staff. Rhythmic markings like '9:8', '3:2', and '5:4' are present. The system is divided into measures numbered 2 through 6.

Handwritten musical score for the third system. It consists of two staves: a treble staff and a bass staff. The treble staff begins with a treble clef and a key signature of one sharp (F#). The bass staff begins with a bass clef and a key signature of one sharp (F#). The score includes various musical notations such as notes, rests, and dynamic markings. Key annotations include 'BG' above the treble staff, '(SEMPLICE)' in the treble staff, and 'mf' in the bass staff. Rhythmic markings like '3:2', '7:8', and '5:4' are present. The system is divided into measures numbered 1 through 4.

Handwritten musical score for the first system. It consists of two staves: a treble staff and a bass staff. The treble staff begins with a treble clef and a dynamic marking of *(mf)*. The bass staff begins with a bass clef and a dynamic marking of *(p)*. The music is written in a complex, rhythmic style with many accidentals (sharps and flats) and slurs. Above the treble staff, there are several annotations: "2 3" above a group of notes, "F=8" above a measure, "A7" above a measure, "3=2" above a measure, and "E3" above a measure. Below the treble staff, there are annotations: "5=4" under a measure, "3=2" under a measure, "p" under a measure, "pp" under a measure, "5=4" under a measure, "3=2" under a measure, "5=4" under a measure, "5=4" under a measure, and "5=4" under a measure. The system ends with a double bar line.

(LIGHTLY)

Handwritten musical score for the second system. It consists of two staves: a treble staff and a bass staff. The treble staff begins with a treble clef and a dynamic marking of *mf/p*. The bass staff begins with a bass clef and a dynamic marking of *(pp)*. The music continues with complex notation, including many accidentals and slurs. Above the treble staff, there are annotations: "3" above a group of notes, "5=4" above a measure, "F3" above a measure, "5=4" above a measure, "E4" above a measure, "5=4" above a measure, and "B7" above a measure. Below the treble staff, there are annotations: "3" under a measure, "5=4" under a measure, "5=4" under a measure, "5=4" under a measure, "5=4" under a measure, "5=4" under a measure, "3=2" under a measure, and "3=2" under a measure. The system ends with a double bar line.

(EMPHATICALLY)

Handwritten musical score for the third system. It consists of two staves: a treble staff and a bass staff. The treble staff begins with a treble clef and a dynamic marking of *p*. The bass staff begins with a bass clef and a dynamic marking of *p*. The music concludes with complex notation, including many accidentals and slurs. Above the treble staff, there are annotations: "5=4" above a measure, "5=4" above a measure, "5=4" above a measure, "5=4" above a measure, "5=4" above a measure, "5=4" above a measure, "3=2" above a measure, "3=2" above a measure, "3" above a measure, and "5=4" above a measure. Below the treble staff, there are annotations: "5=4" under a measure, "5=4" under a measure, "5=4" under a measure, "5=4" under a measure, "5=4" under a measure, "5=4" under a measure, "3=2" under a measure, "3=2" under a measure, "3" under a measure, and "5=4" under a measure. The system ends with a double bar line.

Handwritten musical score for the first system, featuring two staves. The notation includes complex rhythmic patterns with various time signatures and dynamic markings. Above the staff, there are several bracketed time signatures:  $7=8$ ,  $7=8$ ,  $5=4$ ,  $9=8$ ,  $5=4$ , and  $6=3$ . A key signature change to one flat is indicated by  $(\flat)$ . Dynamic markings include  $mf$ ,  $pp$ , and  $p$ . A circled  $7$  is written above the staff. The bottom staff has a circled  $p$  and a  $5=4$  time signature.

Handwritten musical score for the second system, featuring two staves. The notation is dense with complex rhythmic patterns. Above the staff, there are several bracketed time signatures:  $5=4$ ,  $5=4$ ,  $3=2$ ,  $5=4$ ,  $3=2$ ,  $9=8$ , and  $9=8$ . A key signature change to one flat is indicated by  $(\flat)$ . Dynamic markings include  $mf$ ,  $p/f$ ,  $p$ ,  $fz/mf$ , and  $sfz$ . A circled  $7$  is written above the staff. The bottom staff has a circled  $8$  and a  $6=5$  time signature.

Handwritten musical score for the third system, featuring two staves. The notation includes complex rhythmic patterns with various time signatures and dynamic markings. Above the staff, there are several bracketed time signatures:  $7=8$ ,  $9=8$ ,  $5=4$ ,  $3=2$ ,  $3=2$ , and  $5=4$ . A key signature change to one flat is indicated by  $(\flat)$ . Dynamic markings include  $mf$ ,  $sfz$ ,  $mf$ ,  $fz(poco)$ , and  $p$ . A circled  $8$  is written above the staff. The bottom staff has a circled  $8$  and a  $5=4$  time signature.

# EM FUGUE C SHIMMERINGLY

5:4 (7.) 3:2 3:2 (6) 5:4

(Loco) (Loco) (Loco)

mf

5 5 5

(PED) →

(Loco)

(PED) →

3 1/3"

pp

p

(PED) →

Handwritten musical score for the first system. It consists of two staves. The upper staff contains a melodic line with various accidentals and a 'Loco' marking. The lower staff contains a complex accompaniment with many notes and accidentals. A 'ppp' dynamic marking is at the top right. A bracket labeled '5"' spans the right portion of the system. A '(PED)' marking with an arrow is at the bottom left.

Handwritten musical score for the second system. It consists of two staves. The upper staff contains a melodic line with various accidentals and a '(D#)' marking. The lower staff contains a complex accompaniment with many notes and accidentals. A 'pp' dynamic marking is at the top left, and a 'ppp' dynamic marking is at the top right. A bracket labeled '7"' spans the right portion of the system. A '(PED)' marking with an arrow is at the bottom left.

Handwritten musical score for the third system. It consists of two staves. The upper staff contains a melodic line with various accidentals and a 'Loco' marking. The lower staff contains a complex accompaniment with many notes and accidentals. A 'ppp' dynamic marking is at the bottom left, and a 'pppp' dynamic marking is at the bottom center. A bracket labeled '10"' spans the right portion of the system. A '(PED)' marking with an arrow is at the bottom left. The system ends with a double bar line.

ATTACCA K=+1

132

K=+1

♩=42 SEMPLICE

Handwritten musical score for the first system. It consists of a treble staff and a bass staff. The treble staff contains several measures of music with complex rhythmic patterns, including notes with stems and beams. Above the treble staff, there are several horizontal lines with arrows indicating durations:  $5:4$ ,  $5:4$ ,  $9:8$ ,  $9:8$ , and  $9:8$ . The bass staff contains a few notes, with a  $3:2$  marking above the first measure. Dynamics include  $mfz$ ,  $p$ , and  $pp$ . A  $5:4$  marking is also present below the bass staff. The system ends with a double bar line and a  $pp$  marking above the treble staff. Below the staves, there is a dashed line with a circled  $3p$  and a  $(HOLD)$  marking.

$3p$  (PED)

Handwritten musical score for the second system. It consists of a treble staff and a bass staff. The treble staff contains several measures of music with complex rhythmic patterns, including notes with stems and beams. Above the treble staff, there is a  $5:4$  marking. The bass staff contains a few notes, with a  $3:2$  marking above the first measure. Dynamics include  $pp$ . The system ends with a double bar line. Below the staves, there is a dashed line with a circled  $3p$  and a  $(PED)$  marking.

$3p$  (PED)

Handwritten musical score for the first system. The system consists of three staves: Treble Clef (top), Bass Clef (middle), and a lower Bass Clef (bottom). The top staff begins with a treble clef, a key signature of one sharp (F#), and a common time signature (C). It contains a complex rhythmic passage with notes beamed together. A vertical line with a 'V' above it is positioned at the beginning. Below the top staff, there are two horizontal lines with a '5:4' ratio between them. The middle staff starts with a bass clef and a common time signature. It contains a rhythmic passage with notes beamed together. A vertical line with a '1' above it is positioned at the beginning. Below the middle staff, there are two horizontal lines with a '9:8' ratio between them. The bottom staff starts with a bass clef and a common time signature. It contains a rhythmic passage with notes beamed together. A vertical line with a '3:2' ratio between them is positioned at the beginning. The system concludes with a double bar line and a '(HOLD)' marking. Below the staves, there are two horizontal lines with a '3:2' ratio between them. The system is marked with '(PED)' at the beginning and end, and a circled '3p' below the first measure.

mfz (poco) 5:4 5:4 9:8 9:8 5:6 9:8 9:8 3:2 3:2 (HOLD) (PED)

Handwritten musical score for the second system. The system consists of three staves: Treble Clef (top), Bass Clef (middle), and a lower Bass Clef (bottom). The top staff begins with a treble clef, a key signature of one sharp (F#), and a common time signature (C). It contains a complex rhythmic passage with notes beamed together. A vertical line with a '(dx)' above it is positioned at the beginning. Below the top staff, there are two horizontal lines with a '9:8' ratio between them. The middle staff starts with a bass clef and a common time signature. It contains a rhythmic passage with notes beamed together. A vertical line with a '3:2' ratio between them is positioned at the beginning. Below the middle staff, there are two horizontal lines with a '7:6' ratio between them. The bottom staff starts with a bass clef and a common time signature. It contains a rhythmic passage with notes beamed together. A vertical line with a '5:4' ratio between them is positioned at the beginning. The system concludes with a double bar line and a '(HOLD)' marking. Below the staves, there are two horizontal lines with a '3:2' ratio between them. The system is marked with '(PED)' at the beginning and end, and a circled '3p' below the first measure.

(dx) 9:8 9:8 3:2 7:6 5:4 (HOLD) (PED)



Handwritten musical score for the first system. It consists of three staves: Treble, Bass, and a lower Bass staff. The Treble staff contains complex rhythmic patterns with various accidentals and dynamic markings such as *mfz*, *sfz*, *p*, and *f*. Above the Treble staff, there are handwritten annotations including  $5:4$ ,  $7..$ ,  $(G\#)$ ,  $9:8$ ,  $5:4$ ,  $3:2$ ,  $mfz$ , and *mf*. The Bass staff has a circled  $3P$  at the beginning. Below the staves, there are four groups of notes on a dashed line, each labeled  $(PED)$ .

Handwritten musical score for the second system, continuing from the first. It features three staves with complex rhythmic notation and dynamic markings like *mfz*, *sfz*, *p*, and *mf*. Annotations include  $5:4$ ,  $3:2$ ,  $7:8$  (Loco),  $7:8$ ,  $5:4$ ,  $3:2$ ,  $mfz, *mf*, and  $(\infty)$ . A circled  $3P$  is located at the bottom right. Below the staves, there are several groups of notes on a dashed line, with the first labeled  $(PED)$  and others labeled *lp*. An asterisk  $*$  is placed above the first  $(PED)$  group.$

Handwritten musical score for the first system. It consists of three staves. The top staff is in treble clef, the middle in bass clef, and the bottom in bass clef. The music is marked with dynamics *ppp* and *mf*. Time signatures include  $5:6$ ,  $5:4$ ,  $9:8$ , and  $7:8$ . Performance instructions include  $3P$  (circled),  $4PED$ , and  $(HOLD)$ . A large slur covers the first two staves. A dashed line with  $3P$  and  $4PED$  spans the bottom of the system.

Handwritten musical score for the second system. It consists of three staves. The top staff is in treble clef, the middle in bass clef, and the bottom in bass clef. The music is marked with dynamics *mf* and *f (poco)*. Time signatures include  $5:4$ ,  $7:8$ , and  $3:2$ . Performance instructions include  $3P$  (circled),  $4PED$ , and  $(LH)$ . A large slur covers the first two staves. A dashed line with  $3P$  and  $4PED$  spans the bottom of the system.

Handwritten musical score for the first system, consisting of three staves. The top staff contains complex rhythmic patterns with various accidentals and dynamic markings. The middle staff includes dynamic markings: *mf p*, *pp*, *sffz*, *mf*, and *pp*. The bottom staff features a pedal point marked *(PED)* with a circled *3p* below it. Above the staves, there are several horizontal lines with brackets and ratios:  $7:8$ ,  $3:2$ ,  $7:8$ ,  $9:8$ ,  $9:8$ , and  $3:2$ . A large slur covers the entire system, and a circled *(PED)* is written below the bottom staff. An asterisk *\** is placed at the end of the system.

Handwritten musical score for the second system, consisting of three staves. The top staff contains complex rhythmic patterns with various accidentals and dynamic markings. The middle staff includes dynamic markings: *p*, *ff*, *pp*, *ff*, and *pp*. The bottom staff features a pedal point marked *(PED)*. Above the staves, there are several horizontal lines with brackets and ratios:  $5:4$ ,  $5:4$ ,  $5:4$ ,  $7:4$ ,  $9:8$ ,  $5:4$ , and  $3:2$ . A large slur covers the entire system.

Handwritten musical score for the first system, consisting of three staves. The top staff is in treble clef, the middle in alto clef, and the bottom in bass clef. The music is in a key with one sharp (F#). Dynamics include *pp* and *f*. Time signature changes are indicated by brackets above the staves: 9:8, 3:2, and 7:8. A *pp* dynamic is also present in the right-hand section. A *fz* marking is written below the middle staff. A *(PED)* marking is at the bottom left. The system ends with a double bar line and a right-pointing arrow.

Handwritten musical score for the second system, consisting of three staves. The top staff is in treble clef, the middle in alto clef, and the bottom in bass clef. The music is in a key with one sharp (F#). Dynamics include *p* and *pp*. Time signature changes are indicated by brackets above the staves: 3:2, 5:4, and 7:8. A *(HOLD)* marking is written below the middle staff. A *(PED)* marking is at the bottom left. The system ends with a double bar line and a right-pointing arrow.

Handwritten musical score for the first system, consisting of three staves. The top staff is in treble clef, the middle in alto clef, and the bottom in bass clef. The music is marked with various time signatures and ratios: 7:8, 5:4, 3, 9:8, 7:6, 5:4, and 9:8. Dynamic markings include *mfz* and *p*. A circled '8' with a flat is written below the bottom staff. A '(PED)' marking is at the beginning, and '(HOLD)' is written above the bottom staff. The system concludes with a long horizontal line and an arrow pointing right.

Handwritten musical score for the second system, consisting of three staves. The top staff is in treble clef, the middle in alto clef, and the bottom in bass clef. The music is marked with ratios: 9:8, 5:4, 5:4, 7:8, and 5:4. Dynamic markings include *pp* and *ppp*. A circled '8' is written below the bottom staff. The system concludes with a long horizontal line and an arrow pointing right.

Handwritten musical score for the first system. It consists of three staves: a treble clef staff at the top, a middle staff with a common time signature, and a bass clef staff at the bottom. The music is written in a complex, multi-measure style. Above the treble staff, there are time signature markings:  $9:8$  and  $7:6$ , with  $7:8$  appearing below the staff. Dynamics include  $p$  (piano),  $mfz$  (mezzo-forte),  $sfz$  (sforzando), and  $sffz$  (sforzissimo). A circled number  $(30)$  is written below the bass staff. Pedal markings  $(PED)$  are present at the beginning and end of the system. A dashed line indicates a continuation of the piece.

Handwritten musical score for the second system. It consists of three staves: a treble clef staff at the top, a middle staff with a common time signature, and a bass clef staff at the bottom. The music continues from the first system. Above the treble staff, there are time signature markings:  $7:6$ ,  $9:8$ , and  $7:8$ . Dynamics include  $p$  (piano),  $sfz$  (sforzando), and  $pp$  (pianissimo). Chordal markings  $(C\flat)$  and  $(C\sharp)$  are written above the treble staff. Pedal markings  $(PED)$  are present at the beginning and end of the system. A dashed line indicates a continuation of the piece.

Handwritten musical score for the first system, consisting of three staves. The notation is highly complex, featuring numerous accidentals and rhythmic markings. Above the staves, there are several bracketed intervals with ratios:  $9:8$ ,  $3:2$ ,  $5:4$ , and  $9:8$ . A **sfz** (sforzando) marking is placed above the first staff. Below the staves, there are more interval ratios:  $7:6$ ,  $9:8$ ,  $7:8$ ,  $5:4$ ,  $9:8$ , and  $7:8$ . Dynamic markings include **pp** (pianissimo) and **sfz**. Pedal markings **(PED)** are present at the beginning and in the middle of the system. The bottom staff has a circled '8' at the beginning.

Handwritten musical score for the second system, consisting of three staves. The notation continues with complex rhythmic patterns and dynamic markings. Above the staves, there are interval ratios:  $5:4$ ,  $3:2$ ,  $5:4$ , and  $5:4$ . A **mf** (mezzo-forte) marking is placed above the first staff. Below the staves, there are more interval ratios:  $2:8$ ,  $5:4$ ,  $5:4$ ,  $5:4$ ,  $5:4$ , and  $5:4$ . Dynamic markings include **mf**, **f** (forte), **pp**, and **p** (piano). Pedal markings **(PED)** are present at the beginning and end of the system. The bottom staff has a circled '8' at the beginning.

Handwritten musical score for the first system, consisting of three staves. The top staff is marked with a crescendo hairpin and a dynamic marking of  $f$  (poco). The middle staff begins with a dynamic marking of  $mfz$ . The bottom staff includes a  $(HOLD)$  instruction. The score is annotated with various time signatures:  $5:4$ ,  $7:8$ ,  $9:8$ , and  $5:6$ . A  $(PED)$  marking is present at the beginning of the system.

Handwritten musical score for the second system, consisting of three staves. The top staff features a series of notes with dynamic markings of  $sfz$  and  $p$ , and includes circled annotations (Ch), (6), (7), (16), and (3). The middle staff has dynamic markings of  $pp$ ,  $p$ , and  $sfz$ . The bottom staff includes a  $(PED)$  marking and a dynamic marking of  $mf$  (poco). A circled annotation (3p) is located below the bottom staff. The score is annotated with time signatures  $5:4$  and  $9:8$ .



(b)

Handwritten musical score for the first system. It consists of three staves. The top staff has a treble clef and a 5/4 time signature. The middle and bottom staves have bass clefs. The music is marked with *ppp* (pianississimo) at the beginning and *p* (piano) later. Rhythmic markings include  $3:2$ ,  $5:4$ ,  $7:8$ , and  $9:8$ . There are two *(HOLD)* markings in the bottom staff. The system ends with a double bar line and an arrow pointing right.

Handwritten musical score for the second system. It consists of three staves. The top staff has a treble clef and a 5/4 time signature. The middle and bottom staves have bass clefs. The music is marked with *f (poco)* (forzando poco) at the beginning and *p* (piano) later. Rhythmic markings include  $3:2$ ,  $5:4$ ,  $7:6$ , and  $7:8$ . There are four *(HOLD)* markings in the bottom staff. The system ends with a double bar line and an arrow pointing right.

Handwritten musical score for the first system, consisting of three staves. The notation includes various rhythmic values such as 5:4, 7:8, 9:8, and 5:6. Dynamic markings include *pp*, *f*, and *(pp)*. There are also markings for *f* (poco) and *(pp)*. Pedal points are indicated by *(PED)* at the bottom of the staves. The music features complex rhythmic patterns and accidentals.

Handwritten musical score for the second system, consisting of three staves. The notation includes various rhythmic values such as 5:4, 9:8, 7:6, and 3:2. Dynamic markings include *pp*, *mp*, *sfz*, *p*, and *sfz*. There are also markings for *(mp)* and *sfz*. Pedal points are indicated by *(PED)* at the bottom of the staves. The music continues with complex rhythmic patterns and accidentals.

Handwritten musical score for the first system, measures 1-10. The score is written on three staves (treble, middle, and bass clefs). It features complex rhythmic patterns with various time signatures and dynamic markings. Above the staves, there are bracketed annotations for time signatures: 3, 7:6, 5:4, 5:4, 9:8, 3:2, and 9:8. Dynamic markings include *SFZ*, *pp*, *SFFZ*, *p*, *mf*, and *f*. Performance instructions include *(PED)*, *(HOLD)*, and *Lp* with an arrow pointing right.

Handwritten musical score for the second system, measures 11-20. The score continues on three staves. It includes time signature annotations: 9:8, 5:4, 7:6, 5:4, and 7:8. Dynamic markings include *mfz*, *pp*, *mf*, and *ff*. Performance instructions include *(PED)* and *(HOLD)* with arrows indicating duration.

Handwritten musical score for the first system, featuring complex rhythmic patterns and dynamic markings. The score is written on a grand staff (treble, middle, and bass clefs) with a piano (p) dynamic marking at the beginning. The music is characterized by intricate rhythmic structures, including triplets and various time signatures such as 9:8, 5:6, 5:4, and 7:8. A fermata is placed over a note in the middle staff. The piece concludes with a (PED) marking and a (HOLD) instruction. A large slur arches over the entire system.

Handwritten musical score for the second system, continuing the complex rhythmic and dynamic themes. The score is written on a grand staff with a forte (f) dynamic marking at the beginning. It features a variety of time signatures including 9:8, 5:4, 3:2, and 7:8. The notation includes complex rhythmic patterns and dynamic markings such as mf and p. A large slur arches over the entire system, and the piece ends with a (PED) marking.

Handwritten musical score for the first system. It consists of a grand staff (treble and bass clefs) and a piano staff below. The piano staff includes a circled '3P' and a dashed line with '(PED)' at both ends. The grand staff contains several measures with notes and rests. Annotations include '3:2' and '5:4' ratios above and below the staff, and 'ppp' dynamic markings. A circled '3P' is located below the piano staff.

Handwritten musical score for the second system. It consists of a grand staff (treble and bass clefs) and a piano staff below. The piano staff includes a circled '3P' and a dashed line with '(PED)' at both ends. The grand staff contains several measures with notes and rests. Annotations include '(Loco.)' above the staff, 'pppp' dynamic markings, and '5:4' ratios above and below the staff. A circled '3P' is located below the piano staff.

# INFALLSCAPE

$\text{♩} = 54$

pp DEFT, MOTORIC

Handwritten musical score for the first system. It consists of two staves. The upper staff is in treble clef and the lower staff is in bass clef. The music is written in a complex, chromatic style with many accidentals. The first measure of the lower staff is marked with a circled 'pp'. There are several dynamic markings and performance instructions: '(MINIMUM OF PEDAL)' under the first measure, '5:4' with a slur over the first two measures of the lower staff, and '5:4' with a slur over the first two measures of the upper staff. There are also several arrows and other symbols indicating phrasing or articulation.

Handwritten musical score for the second system. It consists of two staves. The upper staff is in treble clef and the lower staff is in bass clef. The music continues with complex, chromatic patterns. There are several dynamic markings, including a circled 'pp' at the beginning of the lower staff. There are also several arrows and other symbols indicating phrasing or articulation.

Handwritten musical score for the third system. It consists of two staves. The upper staff is in treble clef and the lower staff is in bass clef. The music continues with complex, chromatic patterns. There are several dynamic markings, including a circled 'pp' at the beginning of the lower staff. There are also several arrows and other symbols indicating phrasing or articulation. The system ends with a double bar line and a repeat sign.

9417

2 68

534

85(6)

50

2 2 4 2 H  
1 7 2

5C

2G

1H

3G

1I

5:6

Handwritten musical score for the first system, consisting of two staves. The notation includes complex rhythmic patterns with many beamed notes and slurs. Above the staves, there are several annotations: "2 2 4 2 H 1 7 2", "5C", "2G", "1H", "3G", "1I", and "5:6". Below the staves, there are more annotations: "8 6 1 5", "1 5", "2 3 3 (7)", "(9) 6 4 7", and "28". On the far right, there is a circled "3P" and the text "OR LINEAR" with an arrow pointing right. A "ppp" marking is also present near the end of the system.

A TOUCH FASTER

Handwritten musical score for the second system, consisting of two staves. The notation is dense with beamed notes and slurs. Above the staves, there are annotations: "55", "13 3/4", "5G", "5B", "4B", "1F", and "1K". The first staff begins with a "mf" dynamic marking. The system ends with a double bar line.

3P

Handwritten musical score for the third system, consisting of two staves. The notation continues with complex rhythmic patterns. Above the staves, there are annotations: "4G", "3F", "4F", "5E", and "2K". The first staff begins with a "mf" dynamic marking. The system ends with a double bar line.

5J 2J 3E 4E 1J

(mf)

4J 10 1E CH 3D 2E

(mf)

B

4I 5I 2F 4D 5K

(mf) Cresc...

<f>

#C#DEGH  
(PED)



# III SLIGHTLY FASTER, AGAIN.

5F

3C

1G

3K

Handwritten musical score for the first system, measures 5F to 3K. The score is written on two staves. The upper staff begins with a treble clef and a sharp sign. The lower staff begins with a bass clef. The music is in a complex, chromatic style with many accidentals. A dynamic marking *p* is present at the start, followed by *f* and *poco a poco desc...*. A *SHORT!* marking is written above the first few notes. Measure numbers 5F, 3C, 1G, and 3K are written above the staff.

Handwritten musical score for the second system, measures 4K to 3J. The score continues on two staves. The notation is dense with many accidentals and slurs. Measure numbers 4K, 3B, 2B, and 3J are written above the staff.

Handwritten musical score for the third system, measures 2D to 5H. The score continues on two staves. The notation is dense with many accidentals and slurs. Measure numbers 2D, 2I, 3I, 1P, and 5H are written above the staff. The system concludes with dynamic markings *ff* and *f*.

4H

3H

4C

1C

Handwritten musical score for the first system. The top staff is in treble clef and the bottom staff is in bass clef. The music is highly rhythmic and complex, with many accidentals (sharps, flats, naturals) and dynamic markings. A measure number '7.' is written in the bass staff. Above the first staff, there are markings '4H', '3H', '4C', and '1C'. Below the first staff, there are markings '(ch)', '5-4', and '(1/2 p)'. A long horizontal arrow points to the right across the middle of the system.

2C

5D

5C

2G

Handwritten musical score for the second system. The top staff is in treble clef and the bottom staff is in bass clef. The music continues with complex rhythmic patterns and accidentals. A measure number '7.' is written in the bass staff. Above the first staff, there are markings '2C', '5D', '5C', and '2G'. Below the first staff, there is a marking '(ch)'. A long horizontal arrow points to the right across the middle of the system.

3G

sfz

5-4

Handwritten musical score for the third system. The top staff is in treble clef and the bottom staff is in bass clef. The music concludes with a 'PED' marking at the bottom right. Above the first staff, there is a marking '3G'. Below the first staff, there are markings 'sfz' and '5-4'. A long horizontal arrow points to the right across the middle of the system.

# IV VERY SLIGHTLY FASTER, AGAIN

152

Handwritten musical score for guitar and piano, measures 152-157. The score is written on six staves, with the top two staves for guitar and the bottom four for piano. The music is in a complex, rhythmic style with many accidentals and dynamic markings.

Measure 152: **5G** (guitar), **5B** (piano), **4B** (piano), **(G4)** (piano). Dynamics: **sfz**, **f**. Rhythmic markings: **3:2**.

Measure 153: **(ff)** (piano), **ff** (piano), **ff** (piano), **ff** (piano). Rhythmic markings: **3:2**, **(Bb) (E) (A) (G) (F) (D)** (piano).

Measure 154: **(1/2 p)** (piano), **ff** (piano), **ff** (piano), **ff** (piano). Rhythmic markings: **3:2**, **8** (piano).

Measure 155: **(ff)** (piano), **(ff)** (piano), **(ff)** (piano), **(ff)** (piano). Rhythmic markings: **5:3** (piano).

Measure 156: **(ff)** (piano), **(ff)** (piano), **(ff)** (piano), **(ff)** (piano). Rhythmic markings: **7** (piano).

Measure 157: **(ff)** (piano), **(ff)** (piano), **(ff)** (piano), **(ff)** (piano). Rhythmic markings: **7** (piano).

**\* / = SUDDEN DYNAMIC CHANGE**

(57)

$mf$   $f$   $mf$

$3E$   $4E$

$3:4$

$mf$   $f$

$1/2 p$

808

(FROM HERE  $\bar{=}$  .5cm) MARTELLATO! (IN CLEF)

$3D$   $3E$   $4E$   $5I$

$ff$   $fff$

C D E F G A B  $1/2 p$

(51)

(Loco) 2F 4D

8

(ff)

80

809

AS FAST AS POSSIBLE: TUTTA FORZA!

(Loco)

8

(ff)

1/2 p

(PED)

(Loco)

2<sup>ND</sup> 3<sup>RD</sup> 4<sup>TH</sup>

(PED)

THIS SECTION IS PLAYED FOUR TIMES: ON EACH REPETITION THE INITIAL CHORD CHANGES, AS ABOVE.

5<sup>TH</sup> TIME  
(EXACTLY AS BEFORE.)

# TOMBEAU/Ω POINT

GHOSTLY THROUGHOUT — AS IF HEARD FROM A DISTANCE, DREAMLIKE

(Loca) 

$\downarrow = \uparrow$  (L=54)

2 3 4 5

(ABRUPT STOP: NO PAUSE)

(A4) (PED) (KEEP FULLY DEPRESSED THROUGHOUT)

6 7 8 9 10 11



(PED) (UC)

12 13 14 15 16 17 18 19 20

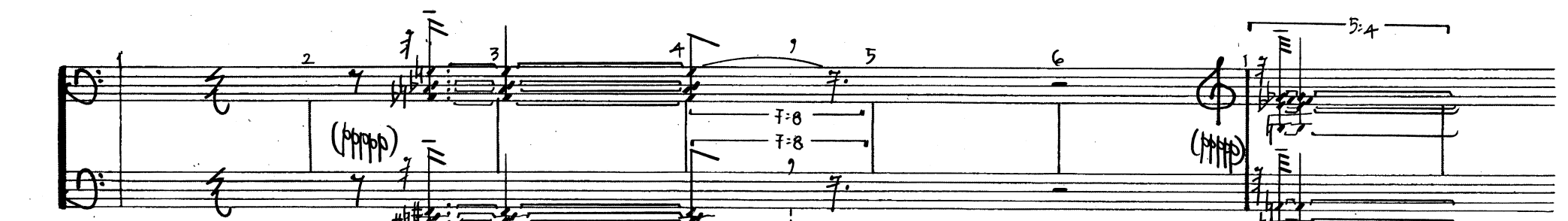

(PED) (UC) 5:4

Handwritten musical score for the first system. It consists of two staves. The top staff begins with a treble clef and a key signature of two sharps (F# and C#). The first measure contains a quarter note G#4 with a finger number '2' above it. The second measure contains a quarter note A4 with a finger number '1' above it. The third measure contains a quarter note B4 with a finger number '3' above it. The fourth measure contains a quarter note C5 with a finger number '4' above it. The fifth measure contains a quarter note D5 with a finger number '5' above it. The sixth measure contains a quarter note E5 with a finger number '6' above it. The seventh measure contains a quarter note F5 with a finger number '2' above it. The bottom staff begins with a bass clef and a key signature of two sharps. The first measure contains a quarter note G#2 with a finger number '5' above it. The second measure contains a quarter note A2 with a finger number '4' above it. The third measure contains a quarter note B2 with a finger number '3' above it. The fourth measure contains a quarter note C3 with a finger number '4' above it. The fifth measure contains a quarter note D3 with a finger number '5' above it. The sixth measure contains a quarter note E3 with a finger number '6' above it. The seventh measure contains a quarter note F3 with a finger number '2' above it. The piece is marked with a dynamic of *(ppppp)* in the second measure. A *(PED)* marking is at the beginning, and a *UC* marking is in the fourth measure. A dashed line indicates the end of the pedal effect.

Handwritten musical score for the second system. It consists of two staves. The top staff begins with a treble clef and a key signature of two sharps. The first measure contains a quarter note G#4 with a finger number '3' above it. The second measure contains a quarter note A4 with a finger number '4' above it. The third measure contains a quarter note B4 with a finger number '5' above it. The fourth measure contains a quarter note C5 with a finger number '6' above it. The fifth measure contains a quarter note D5 with a finger number '1' above it. The sixth measure contains a quarter note E5 with a finger number '2' above it. The seventh measure contains a quarter note F5 with a finger number '3' above it. The bottom staff begins with a bass clef and a key signature of two sharps. The first measure contains a quarter note G#2 with a finger number '5' above it. The second measure contains a quarter note A2 with a finger number '4' above it. The third measure contains a quarter note B2 with a finger number '3' above it. The fourth measure contains a quarter note C3 with a finger number '4' above it. The fifth measure contains a quarter note D3 with a finger number '5' above it. The sixth measure contains a quarter note E3 with a finger number '6' above it. The seventh measure contains a quarter note F3 with a finger number '2' above it. The piece is marked with a dynamic of *(ppppp)* in the first measure. A *(PED)* marking is at the beginning, and a *UC* marking is in the second measure. A *UC* marking is also in the sixth measure. A dashed line indicates the end of the pedal effect. The system concludes with the instruction *ATTACCA 1* and an asterisk.

SOTTO VOCE & GLASSY

(EVENLY)

1

pppp

p L (PED)

3:2 3:2 3:2 3:2 3:2 3:2 3:2 (e. sim.)

(pppp)

(PED)

3:2 3:2

(pppp)

(Loco)

(pppp)

(Loco)

(PED)

3:2



Handwritten musical score for piano, page 158. The score is written on two staves (treble and bass clefs) and includes a pedal line at the bottom. The tempo is marked  $\text{♩} = 66$  and the piece is marked *(poco)*. The dynamics range from *pp* (pianissimo) to *mf* (mezzo-forte). The score is heavily annotated with performance instructions, including numerous slurs and dynamic markings. Rhythmic markings such as  $7:8$ ,  $3:2$ , and  $5:4$  are present throughout the piece, indicating complex rhythmic patterns. A large number '2' is written on the left side of the first staff. The score concludes with a double bar line and a fermata over the final note.

Annotations and markings in the score include:

- Tempo:  $\text{♩} = 66$
- Tempo marking: *(poco)*
- Dynamics: *mf*, *p*, *mf*, *pp*
- Rhythmic markings:  $7:8$ ,  $3:2$ ,  $5:4$
- Performance instructions: *pp*, *mf*, *p*
- Other markings:  $8$ ,  $4$ ,  $5:4$ ,  $3:2$ ,  $7$

$\downarrow = 48$  (GHOSTLY)

3/4

ppp p

5:4 7:8 3:2 5:4

5:4 7:8 3:2 5:4

8

1 1/2 p

SAME TEMPO  
(SUBTERRANEAN)

5

mf pppp

5:4 5:4 5:4 3:2 3:2

5:4 5:4 5:4

8

5

1

(loco)

UC

pppp

3:2 5:4 5:4

UC UC

6

$\downarrow = 46$

pp p

5:4

mfz (poco)

7:6

5:4

pp

5:4

ppp

3p

L(PED)

3p

$\downarrow = \%_6$  (DELICATELY!)

7

Handwritten musical score for the first system. It consists of two staves. The upper staff contains a melodic line with various accidentals and slurs. The lower staff contains a more complex rhythmic accompaniment with many beamed notes. Dynamic markings include *ppp* and *mp*. A large slur covers the entire system. Below the staves, there are performance instructions: "(PED) (FULL)" on the left and " $\downarrow = \%_6$ " on the right.

(SAME TEMPO)

Handwritten musical score for the second system. It consists of two staves. The notation continues with complex rhythmic patterns and slurs. Dynamic markings include *mf*, *pp*, and *ppp*. There are several instances of "5:4" and "3:2" ratios written below the notes. A circled "VC" is at the end of the system. Below the staves, there are performance instructions: " $\downarrow = \%_6$ " on the left and "(PED)" on the right.

Handwritten musical score for the third system. It consists of two staves. The notation continues with complex rhythmic patterns and slurs. Dynamic markings include *pppp*, *pp*, and *ppp*. There are several instances of "5:4" and "3:2" ratios written below the notes. A circled "VC" is at the end of the system. Below the staves, there are performance instructions: "(VC)" on the left and "(PED)" on the right.

$\text{♩} = 60$

DELICATELY

8

Handwritten musical score for the first system. It consists of two staves: a treble clef staff on top and a bass clef staff on the bottom. The treble staff begins with a whole note chord, followed by a series of eighth notes with a slur and a fermata. Dynamics include *pp* and *p*. Fingerings are indicated as 7=8, 3=2, and 5=4. The word "Loco" is written above the treble staff. The bass staff contains a series of chords and notes, with a dynamic of *pp* and a chord marked with a sharp sign and a double sharp sign (A#).

Handwritten musical score for the second system. It consists of two staves: a treble clef staff on top and a bass clef staff on the bottom. The treble staff features a long, flowing melodic line with a slur and a fermata, marked with a dynamic of *ppp*. The word "Loco" is written above the treble staff. Fingerings are indicated as 5=4 and 3=2. The bass staff contains chords and notes, with a dynamic of *ppp* and a chord marked with a sharp sign and a double sharp sign (A#).

9

Handwritten musical score for system 9, measures 1-4. It features a grand staff with treble and bass clefs. The key signature has one flat. The time signature is 6/4. Dynamics include ppp and mf. Rhythmic markings include 5:4, 9:8, and 7:8. There are various accidentals and articulation marks.

10

Handwritten musical score for system 10, measures 5-8. It features a grand staff with treble and bass clefs. The key signature has one flat. Dynamics include pppp and mf. Rhythmic markings include 5:4 and 7:8. There are various accidentals and articulation marks.

11

Handwritten musical score for system 11, measures 9-12. It features a grand staff with treble and bass clefs. The key signature has one flat. The time signature is 4/8. Dynamics include ppp. Rhythmic markings include 5:6, 3:2, 9:8, 5:4, and 7:8. There are various accidentals and articulation marks.

(PED)

164

RALL.

$\downarrow = 96$

12

Handwritten musical score for system 12. It consists of two staves with treble clefs. The first staff begins with a dynamic marking of *mf*. The music features complex rhythmic patterns with many beamed notes and slurs. A *RALL.* (Ritardando) instruction is written above the system with a long, thin wedge indicating a gradual deceleration. Below the staves, there are handwritten annotations:  $(1) \frac{1}{2} \uparrow$  and  $5:4$  ratios. The system concludes with a double bar line and a fermata.

$\downarrow = 90$

Handwritten musical score for system 13. It consists of two staves with treble clefs. The first staff begins with a dynamic marking of *pppp*. The music is characterized by long, sustained notes and complex rhythmic structures. Annotations include  $7:8$  and  $5:4$  ratios, and a circled "UC" with "PED (PULL)" written below it. The system ends with a double bar line and a fermata.

$\downarrow = 60$  WITH SUBTLE RUBATO (SHARPLY)

13

Handwritten musical score for system 14. It consists of two staves with treble clefs. The first staff begins with a dynamic marking of *ppp*. The music features complex rhythmic patterns with many beamed notes and slurs. Annotations include  $3$ ,  $9:8$ , and  $3:2$  ratios, and a circled "LACO" with "PED" written below it. The system concludes with a double bar line and a fermata.

(SAME TEMPO) (sim) MARC. IN p

14

ppp (AS SMOOTHLY AS POSSIBLE)

This system contains the first staff of music. It begins with a treble clef and a key signature of two sharps (F# and C#). The music is written in a complex, rhythmic style with many sixteenth and thirty-second notes. Above the staff, there are several annotations: "(SAME TEMPO)", "(sim) MARC. IN p", and a circled "7". The dynamic marking "ppp (AS SMOOTHLY AS POSSIBLE)" is written below the staff. Above the staff, there are various rhythmic notations including "mfz", "3:2", "5:4", and "7.". The system ends with a double bar line.

POCO RIT. (CLOUDY)

(A TEMPO) 3

(ppp)

This system contains the second staff of music. It continues the complex rhythmic patterns from the first system. Above the staff, there are annotations: "POCO RIT. (CLOUDY)", "mfz", "p", "7", and "(A TEMPO) 3". The dynamic marking "(ppp)" is written below the staff. Above the staff, there are various rhythmic notations including "mfz", "p", "7", and "(A TEMPO) 3". The system ends with a double bar line.

(VERY SHORT)

(ppp)

This system contains the third staff of music. It continues the complex rhythmic patterns from the previous systems. Above the staff, there are annotations: "p", "3:2", "mfz", and "(VERY SHORT)". The dynamic marking "(ppp)" is written below the staff. Above the staff, there are various rhythmic notations including "p", "3:2", "mfz", and "(VERY SHORT)". The system ends with a double bar line.



RALL.

$\text{♩} = 136$  LEGATO, FLOWING - DYING AWAY

15

(PEDAL FOR LEGATO)

$\text{♩} = 104$

L (VC) (3P) L (PED)

16/17

$b = 60$

Handwritten musical score for measures 16 and 17. The top staff is in treble clef with a key signature of two sharps (F# and C#). The bottom staff is in bass clef. The music features complex rhythmic patterns, including triplets and sixteenth notes. Dynamics range from ppp to mfz. Pedal markings (PED) are present at the beginning and end of the system. A tempo marking of  $b = 60$  is at the top left.

Handwritten musical score for measures 18 and 19. The top staff is in treble clef with a key signature of two sharps (F# and C#). The bottom staff is in bass clef. The music continues with complex rhythmic patterns, including triplets and sixteenth notes. Dynamics range from p to f. Pedal markings (PED) are present at the beginning and end of the system. A tempo marking of poco is used.

18

(pp)

(PED.)

*f*

*mf*

*p*

**SLOWER**

7:8

5:4

(NO PAUSE)

19

Handwritten musical score for the first system. It consists of two staves. The upper staff begins with a treble clef and a common time signature. The lower staff begins with a bass clef and a common time signature. The music is characterized by complex rhythmic patterns, with various time signatures indicated above the notes:  $5=4$ ,  $9=8$ ,  $5=4$ ,  $9=8$ ,  $5=4$ ,  $9=8$ ,  $5=4$ , and  $7=6$ . A  $3=2$  marking is also present. Dynamic markings include *p*, *ppp* (with a *(PED)* marking below it), and *mf (poco)*. A large slur covers the entire system, with a *p* marking at the beginning and an *mf (poco)* marking at the end. A fermata is placed over the final note of the upper staff.

Handwritten musical score for the second system. It consists of two staves. The upper staff begins with a treble clef and a common time signature. The lower staff begins with a bass clef and a common time signature. The music continues with complex rhythmic patterns, with time signatures indicated above the notes:  $7=8$ ,  $5=4$ ,  $5=6$ ,  $9=8$ ,  $9=8$ , and  $5=4$ . A  $3=2$  marking is also present. Dynamic markings include *pp*, *mf*, and *ppp*. A *(Loca)* marking is placed above the final note of the upper staff. A large slur covers the entire system, with a *pp* marking at the end. A fermata is placed over the final note of the upper staff. A *(PED)* marking is present at the beginning of the lower staff.

170

$\downarrow = f6$

20

Handwritten musical score for system 20, measures 1-10. The score is written on two staves. The upper staff contains complex rhythmic patterns with various time signatures: 3, 7:5, 5:4, 3:2, 5:4, 5:4, and 5:4. Dynamic markings include *pp*, *mf*, and *pp*. The lower staff contains a bass line with dynamic markings *mf*, *pp*, and *pp*. A *(PED)* marking is present at the beginning.

Handwritten musical score for system 20, measures 11-20. The score continues on two staves. It includes a section marked *(Loco)* and an instruction *(ABRUPT RELEASE)*. Time signatures include 3:2, 5:4, and 7:8. Dynamic markings include *pp*, *mf*, and *pp*. A *(PED)* marking is present at the beginning.

$\downarrow = 96$

RALL.

21

Handwritten musical score for system 21, measures 1-10. The score is written on two staves. The upper staff features a melodic line with slurs and dynamic markings *ppp* and *(Loco)*. The lower staff contains a bass line with dynamic markings *ppp* and *p*. Time signatures include 5:4 and 7:8. A *(PED)* marking is present at the beginning.

$\downarrow = 1/2p$

(PED FULL)

$\downarrow = 76$

Handwritten musical score for the first system, measures 1-8. It features two staves with piano parts and a lower staff with performance instructions. The tempo is marked as quarter note = 76. Dynamics include pppp and ppp. Pedal markings include (PED) and (FULL). A circled 'UC' is present at the end of the system.

$\downarrow = 60$

Handwritten musical score for the second system, measures 9-16. It features two staves with piano parts and a lower staff with performance instructions. The tempo is marked as quarter note = 60. Dynamics include ppp. Pedal markings include (PED). A circled 'UC' is present at the beginning of the system.

22

Handwritten musical score for the third system, measures 17-24. It features two staves with piano parts and a lower staff with performance instructions. Dynamics include ppp and pppp. Pedal markings include (PED). A circled 'UC' is present at the end of the system. The instruction '(NO PAUSE)' is written at the end of the system.

$\text{♩} = 104$  MOLTO LEGATO

172

23

Handwritten musical score for measures 172-181. The score consists of three staves: Treble Clef (top), Treble Clef (middle), and Bass Clef (bottom). The music is marked *MOLTO LEGATO* and includes dynamic markings *pp*, *mf*, and *ppp*. Rhythmic values are indicated by brackets above and below notes, including  $9:8$ ,  $5:4$ ,  $3:2$ ,  $7:8$ , and  $5:6$ . The piece concludes with a fermata and a double bar line.

Handwritten musical score for measures 182-191. The score consists of three staves: Treble Clef (top), Treble Clef (middle), and Bass Clef (bottom). The music is marked *MOLTO LEGATO* and includes dynamic markings *ppp*, *pp*, and *ppp*. Rhythmic values are indicated by brackets above and below notes, including  $5:4$ ,  $9:8$ ,  $3:2$ , and  $7:8$ . The piece concludes with a fermata and a double bar line. The word *(ATTACCA* is written at the end of the score.

24)

# MISTILY - AS BEFORE

24

ACCELL.

RALL.

(SIM.) LOCO

♩ = 57      ♩ = 48 (BEGIN ACCELL.)      ♩ = 96

D#  
C#  
B#  
(FULL RELEASE)



$\text{♩} = 96$

25-  
27

$\text{♩} = 66$  (SOTTO VOCE)  $\frac{3}{2}$

Handwritten musical score for measures 25-27. The top system consists of two staves. The left staff is marked *mf* and the right staff is marked *pp*. The right system is marked *pp* and includes the instruction "(PED) (FULL)". The tempo is  $\text{♩} = 96$ . The right system has a tempo of  $\text{♩} = 66$  (SOTTO VOCE) in  $\frac{3}{2}$  time. The music features complex rhythmic patterns and accidentals.

Handwritten musical score for measures 28-34. The system consists of two staves. The left staff is marked *pp* and includes the instruction "(Leco)". The right staff is marked *pp*. The system includes the instruction "(PED)". The music features complex rhythmic patterns and accidentals, with various time signature changes indicated by brackets:  $\frac{3}{2}$ ,  $\frac{5}{4}$ , and  $\frac{7}{8}$ .

Handwritten musical score for measures 35-41. The system consists of two staves. The left staff is marked *pp* and includes the instruction "(Leco)". The right staff is marked *pp*. The system includes the instruction "(PED)". The music features complex rhythmic patterns and accidentals, with various time signature changes indicated by brackets:  $\frac{5}{4}$ ,  $\frac{9}{8}$ , and  $\frac{7}{8}$ .

(QUASI-ECHO)

28

$\downarrow = 96$

VC

(8 BEATS)

(ATTACCA 29)

$\downarrow = 116$  CRISPLY, DISTANT

29

30

10''

L (PED)

$\flat = 60$  SMOOTHLY, WHISPERED

176

31

Handwritten musical score for the first system, measures 176-188. The score is written on two staves (treble and bass clef). It features a complex rhythmic pattern with many sixteenth notes and rests. Dynamic markings include *ppp* at the beginning and *pp* later in the system. A large slur covers the entire system. A tempo marking  $\flat = 60$  is at the top left. A dynamic marking  $\frac{1}{2}p$  with an arrow is below the first staff.

Handwritten musical score for the second system, measures 189-200. The score is written on two staves. It continues the complex rhythmic pattern. Dynamic markings include *mf* and *pp*. A *Loco* marking is present at the end of the system. A large slur covers the entire system. A dynamic marking  $\frac{1}{2}p$  with an arrow is below the first staff.

Handwritten musical score for the third system, measures 201-212. The score is written on two staves. It continues the complex rhythmic pattern. Dynamic markings include *ppp*. A large slur covers the entire system. A dynamic marking  $\frac{1}{2}p$  with an arrow is below the first staff. The system ends with a thick vertical bar and the text "(NO PAUSE)".

(CATCH MOST OF THE RESONANCE)

SLIGHT ACCELL.  
♩ = 48      9:8      ♩ = 88

32  
33

Handwritten musical score for measures 32 and 33. The score consists of two staves. Above the staves, there are performance instructions: "SLIGHT ACCELL.", "♩ = 48", "9:8", and "♩ = 88". Dynamic markings include "pppp", "pp", and "pppp". Pedal markings include "(PED)", "L 1/2 p", and "(PED) (FULL)". A circled "3p" is at the end of the section. A box highlights a specific rhythmic pattern in the upper staff.

♩ = 96

Handwritten musical score for measures 34 and 35. The score consists of two staves. Performance instructions include "♩ = 96", "pppp", and "(pppp)". Pedal markings include "(LACO)", "(PED)", and "(VC)". A circled "3p" is at the beginning of the section.

3A

♩ = 60

Handwritten musical score for measure 36. The score consists of two staves. Performance instructions include "♩ = 60", "pppp", and "(NO PEDAL)". Pedal markings include "(PED)" and "(VC)". A circled "3p" is at the beginning of the section.

178

$\downarrow = 55$  RALL.

35

Handwritten musical score for the first system, measures 1-10. It features a treble and bass clef staff with complex rhythmic patterns. Above the treble staff, there are tempo markings: "RALL." with a tempo of 55, and "ACCELL." with a tempo of 48. Time signature changes from 9:8 to 7:8 are indicated with brackets. Dynamics include "ppp" and "pp". A fermata is present over the first measure.

(PED.)

(HALF-RELEASE)

SLIGHT ACCELL.

( $\downarrow = 52$ )

Handwritten musical score for the second system, measures 11-20. It continues the musical notation from the first system. Tempo markings include 53, 48, and 52. Time signature changes from 9:8 to 7:8 are shown. Dynamics include "ppp". A fermata is present over the final measure, which is marked with an asterisk (\*).

(PED.)

(AH)

\*

$\text{♩} = 52$

(COUNT THROUGH)

(ATTACCA 36)

Handwritten musical score for the first system, measures 1-36. The score is written on a grand staff with treble and bass clefs. The key signature has one sharp (F#). The tempo is marked as quarter note = 52. The dynamic is pppp. There are handwritten annotations including "5:4" time signatures and "VC (PED)".

$b = 48$

36

Handwritten musical score for the second system, measures 37-72. The score is written on a grand staff with treble and bass clefs. The key signature has one sharp (F#). The tempo is marked as quarter note = 48. The dynamic is mf (poco). There are handwritten annotations including "7:8", "5:4", and "p".

Handwritten musical score for the third system, measures 73-108. The score is written on a grand staff with treble and bass clefs. The key signature has one sharp (F#). The tempo is marked as quarter note = 48. The dynamic is mf (poco). There are handwritten annotations including "9:8", "7:8", "5:4", and "p".

$\text{♩} = 94$  LEGATO  
CANTABILE

37

(PEDAL FOR LEGATO)

(SLIGHTLY DETACHED)

$\text{♩} = 84$  *ff* 7.

3P

38

Handwritten musical score for measure 38. The score is written on two staves (treble and bass clefs). It features complex rhythmic patterns with various time signatures and ratios indicated above the notes, such as 3:2, 5:4, 9:8, 5:6, and 2:8. Dynamic markings include *pp*, *ppp*, *ff*, and *p*. There are also performance instructions like *(A4)* and *(3P)*. The notation includes many accidentals (sharps and flats) and slurs.

39

Handwritten musical score for measure 39. The score is written on two staves. It shows a transition with dynamic markings *ppp* and *pppp*. Time signatures and ratios like 3:2 and 5:4 are present. A large, diagonal line across the bottom of the staves indicates a significant change or crescendo. There are also performance instructions like *(3P)*.

40

Handwritten musical score for measure 40. The score is written on two staves. It includes the performance instruction "EXPLOSIVELY!! WHISPERED" in large, bold letters. There are also markings like "x5" and "♩=56". Dynamic markings include *ppp*, *pppp*, and *pp*. Performance instructions like *(PED.)* and *(P)* are present. The notation includes complex rhythmic patterns and accidentals.



Handwritten musical score for the first system. It consists of a piano staff (top) and a grand staff (middle and bottom). The piano staff begins with a treble clef, a key signature of one sharp (F#), and a common time signature (C). It contains two measures of music, each marked with a dynamic of *ppp* and *mp*. A bracket labeled "5=A" spans the first two notes of the first measure. The grand staff contains two staves, both with a common time signature (C). The upper staff has a treble clef and a key signature of one sharp (F#), while the lower staff has a bass clef and a key signature of one sharp (F#). The first two measures of the grand staff are marked with a dynamic of *pppp*. A circled "UC" is written below the first measure of the grand staff. Below the grand staff is a dashed line with an arrow pointing right, labeled "(PED)".

Handwritten musical score for the second system. It consists of a piano staff (top) and a grand staff (middle and bottom). The piano staff begins with a treble clef, a key signature of one sharp (F#), and a common time signature (C). It contains two measures of music, each marked with a dynamic of *f*. A bracket labeled "7=8" spans the first two notes of the first measure. The grand staff contains two staves, both with a common time signature (C). The upper staff has a treble clef and a key signature of one sharp (F#), while the lower staff has a bass clef and a key signature of one sharp (F#). The first two measures of the grand staff are marked with a dynamic of *f*. A circled "UC" is written below the first measure of the grand staff. Below the grand staff is a dashed line with an arrow pointing right, labeled "(PED)". To the right of the grand staff, a thick vertical bar is followed by the instruction "(ATTACCA 41)".

41

Handwritten musical score for measure 41. The score is written on a grand staff (treble and bass clefs). Above the staff, there are tempo markings:  $\text{♩} = 48$  at the beginning,  $\text{♩} = 52$  (LACO) in the middle, and  $\text{♩} = 48$  at the end. There are also annotations for  $9:8$  ratios and  $(SIM)$  markings. Below the staff, there is a  $(PED.)$  marking with a  $7:8$  ratio. The piece ends with a key signature change to D major (D4, C4, B3) and a final  $7:8$  ratio.

42

Handwritten musical score for measure 42. The score is written on a grand staff (treble and bass clefs). Above the staff, there is an  $(ACCELL)$  marking and a  $9:8$  ratio. Below the staff, there is a  $(PED.)$  marking with a  $7:8$  ratio, and  $(ABRUPT CLEAR)$ . The score includes dynamic markings like  $mf$ ,  $p$ ,  $f$ , and  $mf$ , and a  $5:4$  ratio. The piece concludes with a  $3:2$  ratio and a  $7:8$  ratio.

184

(♩ = 53)

43

Musical score for measure 43. The system consists of a grand staff (treble and bass clefs) and a piano pedal line. The grand staff contains a melodic line with various intervals and a bass line with chords. Above the grand staff, interval markings are present:  $7:8$ ,  $3:2$ ,  $5:4$ ,  $3:2$ ,  $7:8$ , and  $7:8$ . The piano part includes dynamic markings *mf* and *pp*. The pedal line shows four distinct pedal points, each labeled *(PED)*, with a circled *3p* below the first one.

44

Musical score for measure 44. The system consists of a grand staff and a piano pedal line. The grand staff features a melodic line with a large slur and a bass line with chords. An interval marking  $5:4$  is shown above the first part of the measure. The piano part includes dynamic markings *p* and *pp*. The pedal line shows two pedal points labeled *(PED)*, with a circled *3p* below the second one.

Musical score for measure 45. The system consists of a grand staff and a piano pedal line. The grand staff contains a melodic line with a large slur and a bass line with chords. Interval markings  $5:4$  are placed above the melodic line. The piano part includes dynamic markings *ppp*. The pedal line shows two pedal points labeled *(PED)*, with a circled *3p* below the first one and a circled *(B4)* below the second one.

45

$\downarrow = 50$   
 $9:8$   
 $\downarrow = 48$  (NO ACCELL.)  
 $9:8$

ppp  
pppp  
(PED)  
7:8  
7:8

$9:8$   
 $9:8$

pppp  
(PED)  
7:8  
7:8

(PED.)

$\downarrow = 48$

pppp  
pppp  
(PED)  
(UC)  
(ATTACCA 46)

POCO RALL.

♩ = 86

3:2

186

mf

46

♩ = 80

3:2

5:4

3

5:6

5:4

5:4

(PED)

B FG Bb Bb Db Eb

Eb FG# B C#

♩ = 76

ppp

5:6

3:2

3:2

5:4

8

♩ = 69

(PED)

♩ = 86

pppp

7.

(PED)

(POCO ACCEL.)

Handwritten musical score for the first system. It features a treble and bass clef staff with complex rhythmic notation. Above the staff, there are tempo markings:  $\downarrow = 48$  and  $\downarrow = 80$ . A bracket labeled "(LACO) 9=8" spans a section of the music. Other markings include "8", "5:4", and "7=8". A circled "3p" is written below the staff. A dashed line with an arrow points to the right, labeled "L (PED)".

Handwritten musical score for the second system. It continues the treble and bass clef staff notation. Above the staff, there are tempo markings: "(POCO RALL)" and "5:4". Dynamic markings include "pp", "p", "mf", and "pp". A circled "3p" is written below the staff. A dashed line with an arrow points to the right, labeled "L 1/2p".

1 JANUARY 2015-  
 2:30 AM 14 APRIL 2016

Published by



Pterosaur Press  
Melbourne, Australia  
2016

Copyright © Chris Dench 2016

